



Fendalton
Assembly Instructions
1BBB

STANDARD



Kitset Care Guide



www.duratuf.co.nz/lifestyle

Ref:	STANDARD
Frame size:	3150W x 1000D
Model:	DLL3110
Variant:	1BBB

Template Version

v3.0 - ST

Section

- 1.0 **Contents**
- Before you start**
- 2.1 Before you start
- 2.2 Required Tools
- Parts Lists**
- 3.1 Timber List
- 3.2 Cladding List
- 3.3 Flashings, Doors, Windows
- 3.4 Hardware List
- Base Specifications**
- 4.1 Raised Concrete Base
- Timber Framing**
- 5.1 Timber Framing - General
- 5.2 Front and Back Walls
- 5.3 Left and Right Walls
- 5.4 DPC
- 5.5 Wall Frame Installation
- 5.8 Frame Finishing
- Wall Cladding**
- 6.1 Cladding - General
- 6.2 Front and Back Wall Cladding
- 6.3 Left and Right Wall Cladding
- 6.6 Flashings & Gutter Attachment
- Roof installation**
- 7.1 Roof Installation
- 7.2 Ridge & Barge Flashings
- Roller Door Installation**
- 8.1 Roller Door Parts List
- 8.2 Bracket Installation
- 8.3 Door Placement
- 8.4 Fitting Guides and Handle
- 8.5 Fitting Centre Lift Lock
- 8.6 Door Troubleshooting
- Warranty**
- 9.1 Lifestyle Shed TripleTuf® Warranty

2.1 Before you start

Please read this section carefully before beginning!

Kitset Care Guide

If you are not assembling your shed immediately, please refer to our Kitset Care Guide. You may find it using this QR code:

Kitset Care Guide



General Information

- This shed is not designed to be compliant for habitable use.
- Take note of any regulations regarding shed location in relation to boundaries etc.
- Engineering drawings and producer statements are available on the Duratuf website for those sheds that may require them for Building Consent purposes.
- Exemptions from a requirement for a Building Consents are available in many situations; refer to the information on these web pages:

Single-storey detached buildings not over 10 square metres (floor area inside framing)



Single-storey detached buildings between 10 & 30 square metres (floor area inside framing)

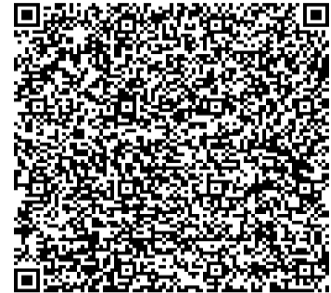

Safety Precautions

- ! Two or more persons or mechanical aids may be required to handle Kitset packages.
- ! Do not attempt to build your shed in windy conditions.
- ! Wear work gloves, and ear and eye protection while assembling.
- ! Be cautious of sharp edges when handling parts.
- ! Use electric tools with care. Always use a Residual Current Device for protection when using mains voltage tools or equipment outdoors.
- ! Ensure safety requirements are met when working with ladders, see:

Safety requirements when working with ladders:



Site Preparation

- The site must be level, with access around all sides of the shed for installation.
- Be aware that sheds under overhanging trees may require additional maintenance to prevent lichen growth and blocked gutters etc.
- A raised concrete slab is the best substrate for a Duratuf Lifestyle shed but must be prepared and poured at least a week before shed assembly.

Warranty Precautions

Your Lifestyle shed is covered by our **Triple Tuf®** Warranty. There are minimum maintenance requirements for your warranty to be valid. For more information, refer to the back page of these instructions, or use these QR codes:

Warranty
Information:



Warranty
Registration:



Assembly Care Instructions





The following warranty requirements must be carefully observed during installation:

- The shed must be installed on a level concrete base, or other solid supports, at least 40mm above ground level.
- Prevent contact between shed cladding and components with soil, vegetation, organic matter, fertilizers, or other chemicals or moisture retaining substances at all times. Prevent contact with cement or wet concrete.
- All metal swarf must be cleaned off the shed IMMEDIATELY as it will quickly initiate corrosion. This includes swarf trapped between steel sheets.
- Do not mark cladding with a graphite pencil, as this may initiate corrosion.
- Do not allow the slightest trace of sunscreen to come into contact with coloured cladding as it will cause discolouration over time. Always use gloves when handling steel.

Preparing to assemble

- Please read all instructions carefully before beginning!
- All dimensions are in millimetres.
- Ensure you have all the tools required, refer to the list on the following page.
- Check all the parts shown in the Parts Lists in Section 3 are included in your kitset and have not been damaged during transit. If replacement parts are required, please notify Duratuf before commencing assembly.
- Two persons are required for safe shed assembly.
- Remove the protective film from all flashings and coloured steel components prior to installing them.

You will need the following tools which are not supplied with your kitset:

<p>Riveter</p> 	<p>Pipe Wrench</p>  <p>For Roller Door installation</p>	<p>Caulking Gun</p> 
<p>Tin Snips (LH & RH)</p> 	<p>Hacksaw</p> 	<p>Adjustable Spanner</p> 
<p>Flat File</p> 	<p>Hand saw</p> 	<p>Hammer</p> 
<p>Utility Knife</p> 	<p>Spirit Level</p> 	<p>Hex Drive Bits</p>  <p>5/16" and 3/8" sizes</p>
<p>Drive Bits</p>  <p>Square drive #2</p>	<p>Drill bits</p>  <p>3.5, 7, 8, 10, and 13mm</p>	<p>Masonry Bits</p>  <p>10 and 12mm</p>
<p>Tape Measure</p> 	<p>Cordless Drill / Screwdriver</p> 	<p>Ladder</p> 
<p>String Line</p> 	<p>Hammer Drill</p>  <p>For concrete bases</p>	

3.1 Timber List

Fendalton - 1BBB

STANDARD

TIMBER FRAMING



Picked by:

Checked by:

Total Timber Framing Pieces: 35

Ref		Code	Description	Length	Qty	✓
T01	Bottom Plate, Front & Back	T3F70-3150	H3 Framing 70x45 3150mm	3150	2	
T02	Top Plate, Front & Back	T3F70-3150	H3 Framing 70x45 3150mm	3150	2	
T03	Top Plate Packer	T3F70-3150	H3 Framing 70x45 3150mm	3150	1	
T04	Lintel	T3F70-2490	H3 Framing 70x45 2490mm	2490	2	
T05	Studs, Front Wall	T3F70-2250	H3 Framing 70x45 2250mm	2250	4	
T06	Door Trimming Studs	T3F70-1895	H3 Framing 70x45 1895mm	1895	2	
T07	Lintel Jack Studs	T3F70-0265	H3 Framing 70x45 265mm	265	3	
T08	Nog, Front (LH)	T3F70-0240	H3 Framing 70x45 240mm	240	1	
T09	Nog, Front (RH)	T3F70-0240	H3 Framing 70x45 240mm	240	1	
T11	Studs, Back and Sides	T3F70-2250	H3 Framing 70x45 2250mm	2250	8	
T14	Nog, Back	T3F70-1155	H3 Framing 70x45 1155mm	1155	1	
T15	Nog, Back, Outer	T3F70-0908	H3 Framing 70x45 908mm	908	2	
T21	Bottom Plate, Sides	T3F70-0860	H3 Framing 70x45 860mm	860	2	
T22	Top Plate, Sides	T3F70-0860	H3 Framing 70x45 860mm	860	2	
T24	Nog, Side	T3F70-0770	H3 Framing 70x45 770mm	770	2	

3.2 Cladding List

Fendalton - 1BBB

STANDARD



Picked by: Checked by:

Total No. of Sheets: 20

Ref		Code	Description	Length	Qty	✓
C01	Wall Sheets, Front Top	CCC4-3150H	Corrug Col 0.4 3150mm Half Sheet	3150	1	
C02	Wall Sheets, Front LH	CCC4-375	Corrugate Col 0.4 375mm	375	3	
C03	Wall Sheets, Front RH	CCC4-375	Corrugate Col 0.4 375mm	375	3	
C11	Wall Sheets, Back (1)	CCC4-3150	Corrugate Col 0.4 3150mm	3150	1	
C12	Wall Sheets, Back (2A)	CCC4-3150	Corrugate Col 0.4 3150mm	3150	1	
C15	Wall Sheets, Back (3A)	CCC4-3150	Corrugate Col 0.4 3150mm	3150	1	
C21	Wall Sheets, LH Side (1)	CCC4-1000	Corrugate Col 0.4 1000	1000	1	
C22	Wall Sheets, LH Side (2A)	CCC4-1000	Corrugate Col 0.4 1000mm	1000	1	
C25	Wall Sheets, LH Side (3A)	CCC4-1000	Corrugate Col 0.4 1000mm	1000	1	
C31	Wall Sheets, RH Side (1)	CCC4-1000	Corrugate Col 0.4 1000mm	1000	1	
C32	Wall Sheets, RH Side (2A)	CCC4-1000	Corrugate Col 0.4 1000mm	1000	1	
C35	Wall Sheets, RH Side (3A)	CCC4-1000	Corrugate Col 0.4 1000mm	1000	1	
C41	Roof Sheets	CCC4-1100	Corrugate Col 0.40 1100mm	1100	4	

OPTIONAL CLEAR ROOF PANEL

Picked by: Checked by:

Ref		Code	Description	Length	Qty	✓
C42	Clear Roof Panel	CTC24-1100	Translucent Corrugate 1100mm	1100		
H13	Dome Washers for Clearlites	XWD32	Dome Washer for Clear Roof Sheets	EA		

Reduce Steel Roof Sheet Qty by 1 for every Clear Roof Panel.

Add 8 x Dome washers per Clear Roof Panel.

FLASHINGSPicked by: Checked by:

Total No. of Flashings: 13

Ref	Code	Description	Length	Qty	✓	
F01	Front Corner Flashing	FLCC-2365	Corner Flashing 95x95 2365mm	2365	2	
F03	Door Top Flashing	FLCDT-2600	RD Top Flashing 86x30 2600mm	2600	1	
F04	Door Head Flashing	FLCDH70-2400	RD Head Flashing 70mm 2400mm	2400	1	
F05	Door Jamb Flashing	FLCDJ70-1970	RD Jamb Flashing 70mm 1970mm	1970	2	
F11	Back Corner Flashing	FLCC-2365	Corner Flashing 95x95 2365mm	2365	2	
F22	Gutter	FLCG100-3265	Gutter 100x100x75 3265mm	3265	1	
F23	Ridge Flashing	FLCR-3265	Ridge Flashing 1xSE 3265mm	3265	1	
F24	Barge Flashing	FLCB100-1188	Barge Flashing 100x180 1188mm	1188	2	
F27	Gutter Straps	FLCGS-200	Gutter Strap Col 200mm	200	1	

DOORS AND WINDOWSPicked by: Checked by:

Ref	Code	Description	Length	Qty	✓	
D01	Roller Door	JRD220-240	Roller Door 2200 High x 2400 Wide	2400	1	

3.4 Hardware List

HARDWAREPicked by: Checked by:

Ref		Code	Description	Length	Qty	✓
H01	Framing Screws	XSWCG10-75	Woodscrew Csk Galv 10g x 75mm	EA	160	
H02	Long Framing Screws	XSTHG14-100	Type 17 Screw Galv 14gx100mm	EA	16	
H03	Fixing Clouts	XNCG25-30	Galv Clout 2.5 x 30mm	EA	100	
H05	Wall Cladding screws	XSRT25N	Cladding Screw with Neo 25mm	EA	200	
H06	Roofing Screws	XSRS55N	Roof Screw with Neo 55mm	EA	60	
H07	Rivets	XRTC4-3	Rivet Truss Head Coloured 4-3	EA	70	
H15	Long Clouts	XNCG28-50	Galv Clout 2.8 x 50mm	EA	20	

ACCESSORIESPicked by: Checked by:

Ref		Code	Description	Length	Qty	✓
A06	DPC Strip	HMDP75-30	Damp Proof Course 75mm x 30m	EA	1	
A22	Touchup Paint	HCPV	Paint Vial	EA	1	
A23	Touchup Brush	HCPB	Paint Brush	EA	1	

A raised concrete slab is the ideal base to prevent water running inside the shed.
A concrete floor must be prepared and poured at least a week before shed assembly.

- **Ground preparation:**
 - Concrete base should be laid on a solid or compacted base. It is recommended to provide at least 75mm of compacted granular fill under the slab.
 - Place 250-micron polythene DPC between the slab and the substrate.
- **Slab dimensions:**
 - Refer to the plan below for the length and width of your concrete slab.
 - Slab to be 20mm less in width and length than the shed Frame size.
 - 80mm min thick slab with 100mm thickened edges as per detail
 - Floor level to be 50mm minimum above ground level.
 - Slab sides to be straight, and diagonal dimensions equal, to ensure squareness!

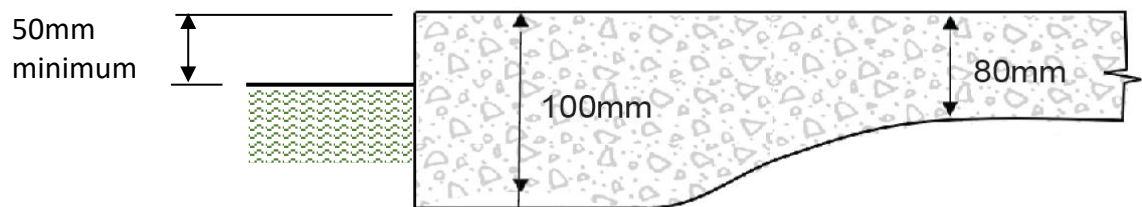

- **Door Rebate:**
 - Rebates should be formed in the concrete at doorways to enhance weather proofing
 - Rebates to be the same width as the door, and slope down 20mm over a 150mm depth
 - The plan below shows the dimensions for a concrete slab for a 'Fendalton' shed with a roller door rebate.

PLAN

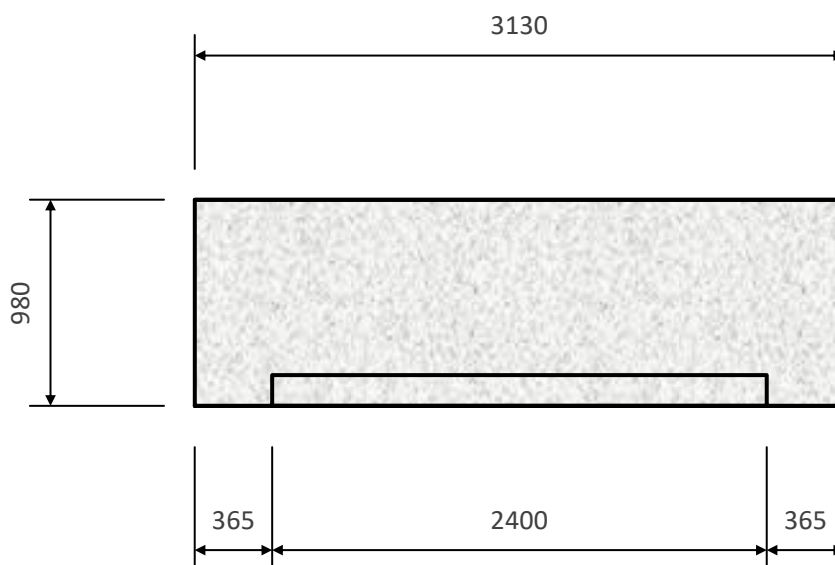

- **Framing Joints**

- Use two **H01** 10g x 75mm countersunk head galvanized screws per joint.



- Fasten studs to plates with two screws through the plates into the stud ends.
- Fasten noggs to studs with two screws skewed through the nog into the stud.

- **Wall Panel Assembly:**

- Assemble each wall frame as a single panel, as shown in Sections 5.1 and 5.2.
- Each panel is shown as observed from the **OUTSIDE** of the shed.
- Each frame member has a reference linked to the timber list in Section 3.1.
- These are shown as blue characters in a square frame, e.g.-



- **Assembly Sequence:**

- For each wall panel, firstly layout the top and bottom plates on a flat surface.
- Fasten the two outer studs between the top and bottom plates and fasten.
- Position the remaining full-length studs.
- Check the distance between each stud; use the noggs as spacers. Fasten studs to plates.
- Fasten the noggs in place at the correct height.
- End noggs may need to be trimmed due to variations in stud thickness.

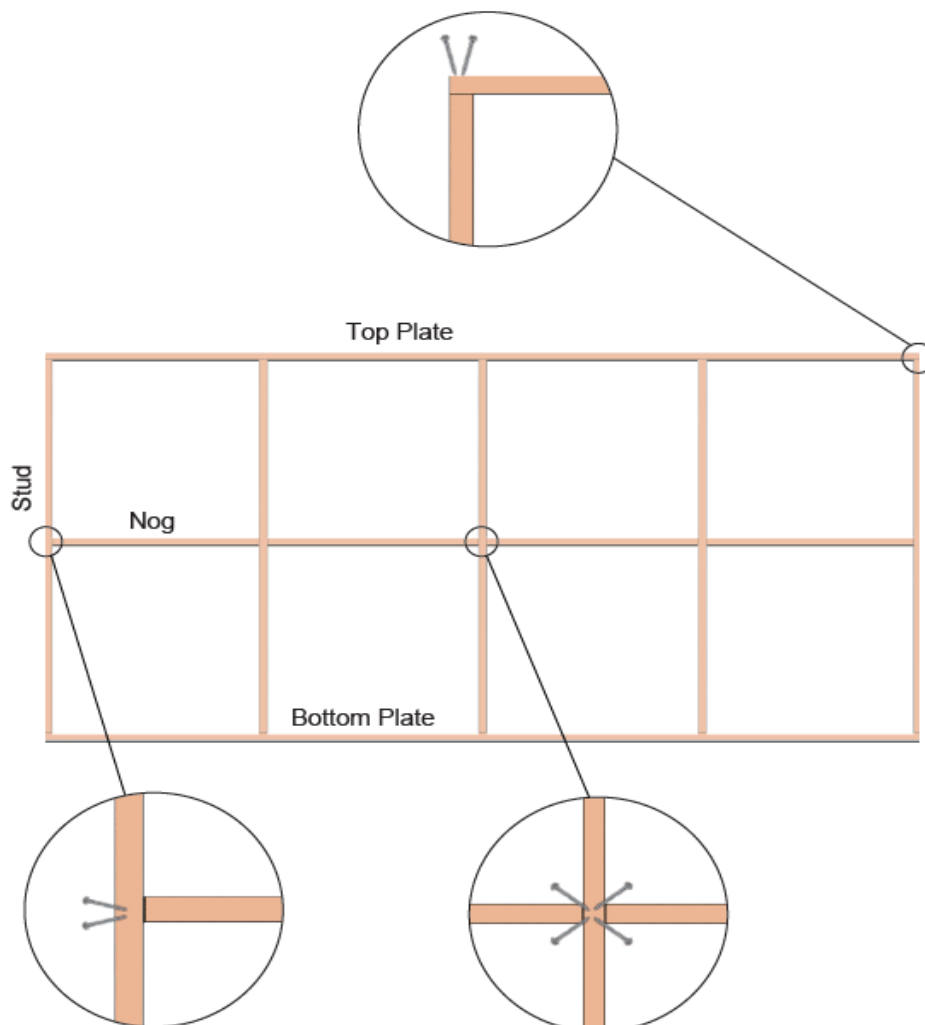

FRONT WALL FRAMING LAYOUT

- Assemble the front wall framing shown below.
- Refer to **Section 5.1** for general instructions on wall framing assembly.
- There are two lintel members, **T04**, one lies one on top of the other. Screw the Jack studs, **T07**, to the upper lintel member then screw the lower lintel member to it.
- Join each pair of double studs either side of door with 8 x screws at 250mm centres.
- The roof can slope either direction, either falling to the front or falling to the back. Determine which direction you want the roof to slope.
- **To slope roof to the back, place T03 Packer flat on the top of Front Wall T02 top plate as shown below. To slope to the front, place packer on Back Wall T02 Top Plate.** Screw through the packer to secure to the plate with 5 x screws.

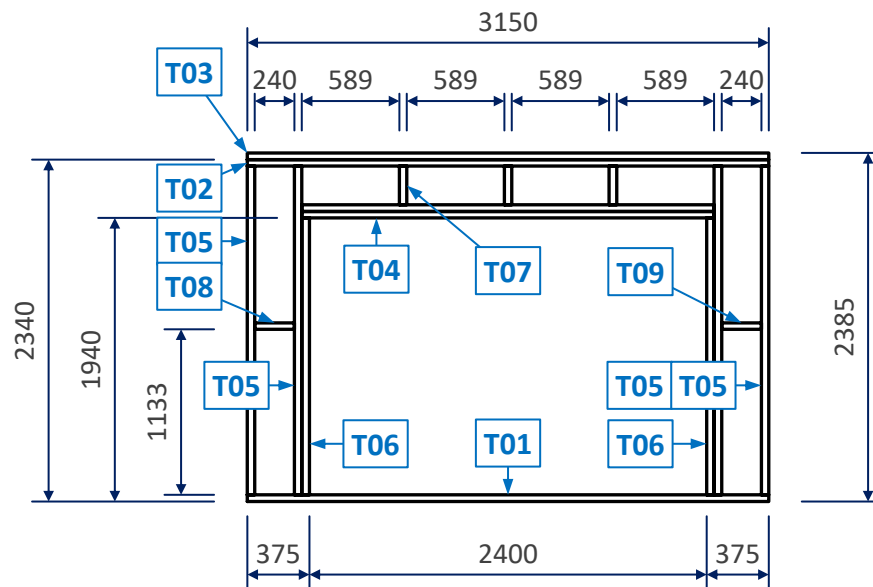
**BACK WALL FRAMING LAYOUT**

- Refer to Section 5.1 for general instructions on wall framing assembly.

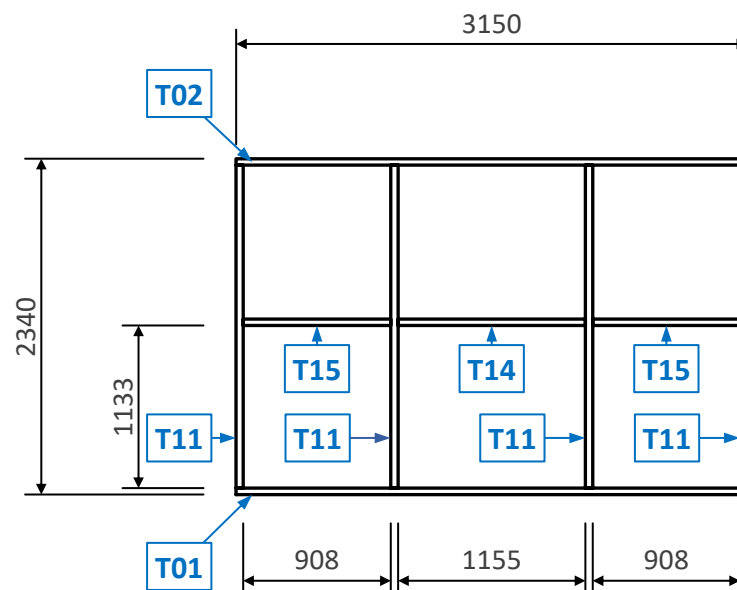

LEFT WALL FRAMING LAYOUT

- Refer to Section 5.1 for general instructions on wall framing assembly.

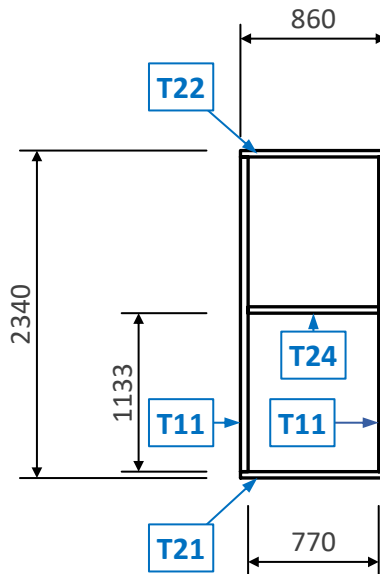

RIGHT WALL FRAMING LAYOUT

- Refer to Section 5.1 for general instructions on wall framing assembly.

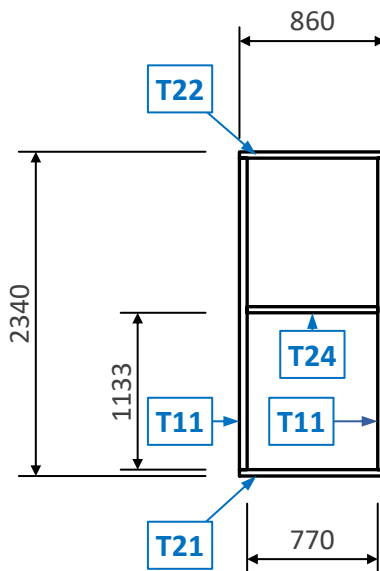

DPC STRIPS

- **Components Required**

- **A06** DPC roll
- **H03** 2.5 x 30mm fixing clouts



- **Attach DPC to Underside of Bottom Plates**

- Only attach the DPC (Damp Proof Course) after all Stud Ties have been fixed in place.
- Cut a strip of DPC material to the length of each wall panel but omit DPC under door opening, as the bottom plate will be removed from here later in construction.
- Use **H03** fixing clouts at each stud to nail the strip to the underside of the bottom plate.
- The strip should be flush with the *outer* edge of the bottom plate.

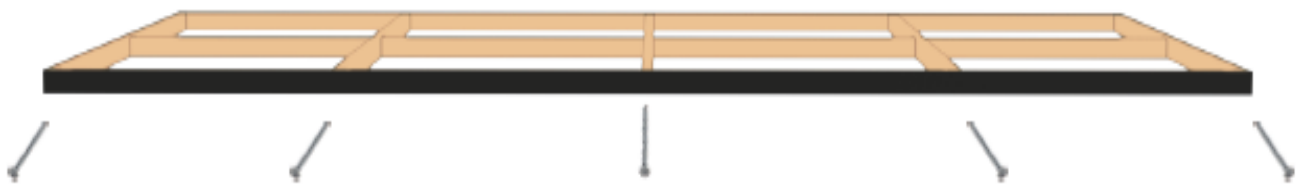

JOINING THE WALL FRAMES

- **Stand the Frames**

- Stand the walls up on the base, in the correct relation to each other as shown below.
- Use temporary braces to safely secure the walls in position while the corners are jointed.
- Note that the Left and Right walls fit *between* the Front and Back Walls.

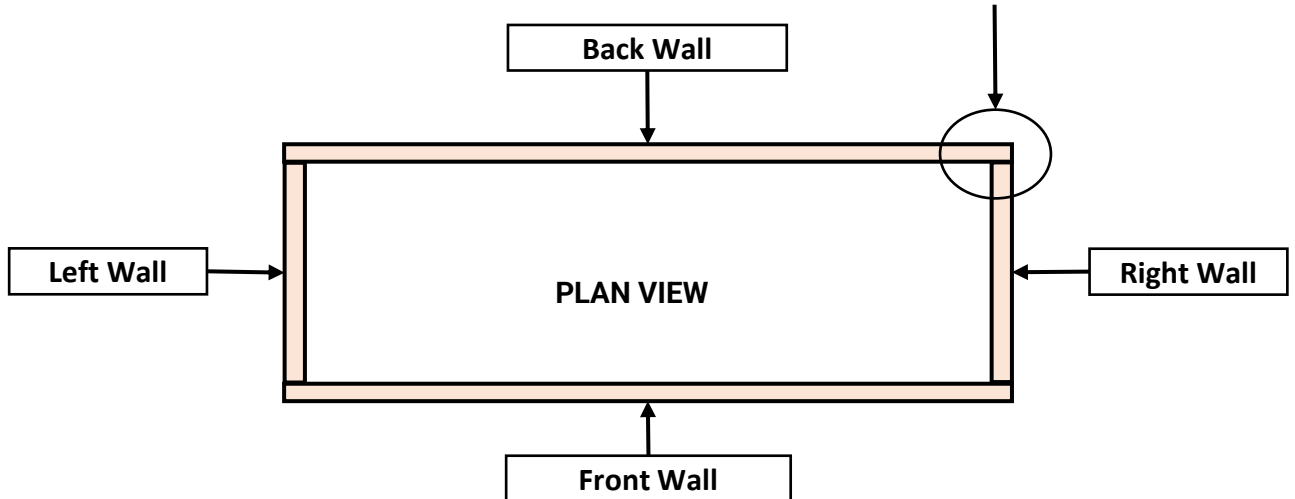

- **Join Frames at Corners**

- Find the **H02 14g x 100mm Hex Head Screws**



- Pre-drill four 7.0mm diameter holes in the outer studs of the side-wall frames *only*, spaced evenly over the height of the stud, and **22mm** in from the outer edge of the stud.

- At each corner, insert **H02 14g x 100mm Tek Screws** through the pre-drilled holes.

- Use the cordless drill and 3/8" drive bit to screw into the end studs on the front and back walls.

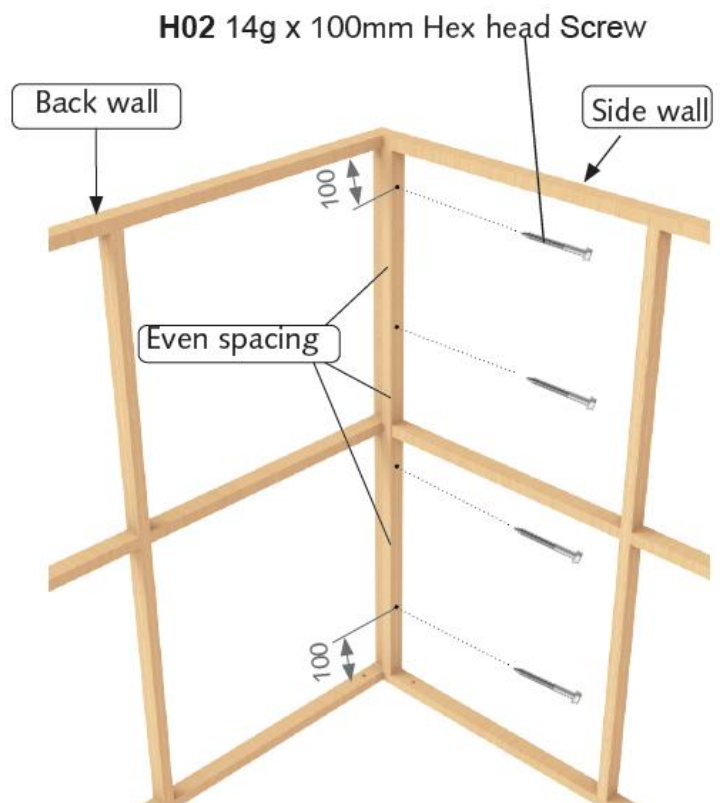

- **Position the Frames**

- First, position the framing so that it overhangs the slab equally (about 10mm) on opposite sides; left and right; and front and back.

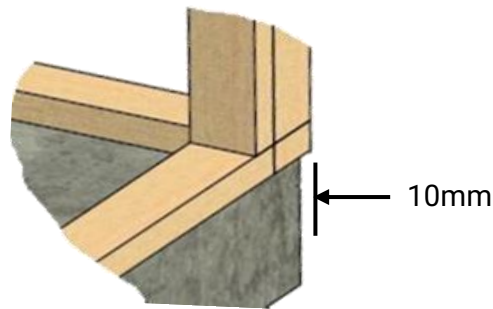

- Adjust the framing position if necessary to ensure the *diagonal* measurements from corner-to-corner are *equal*. This ensures the frame is square.

SECURING BOTTOM PLATE TO THE BASE

- **For all Base Types**

- The bottom plate must be secured to the base with a fastener adjacent to each stud.

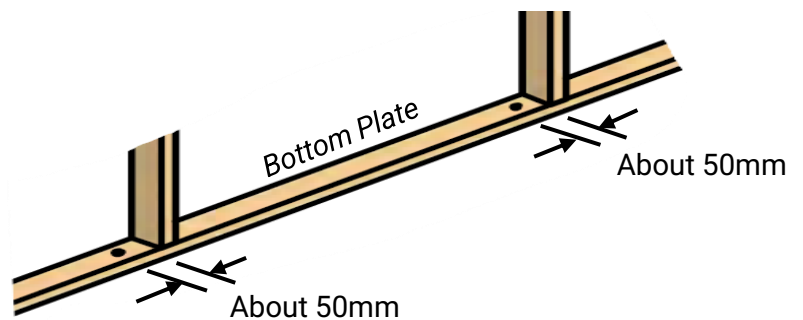

- **For Concrete Bases**

- Use M12 x 135mm Through-Bolts (not supplied)



- Pre-drill a 13mm hole in the bottom plate within 50mm of one side of the stud.

- Use hammer drill and **12mm masonry** bit to drill into concrete base to 140mm depth. Clean out hole of dust and debris. Insert the Through-Bolt full depth. Tighten with spanner.

- **For Timber Bases (where applicable)**

- Use the Timber Screws supplied with your Base Kit and follow the Kit instructions.



COMPLETE FRAMING ASSEMBLY

The completed wall framing assembly should now look like this:

Note: If you have a Very High Wind Zone (VHWZ) kit, install it now; refer to the instructions with the VHWZ kit.

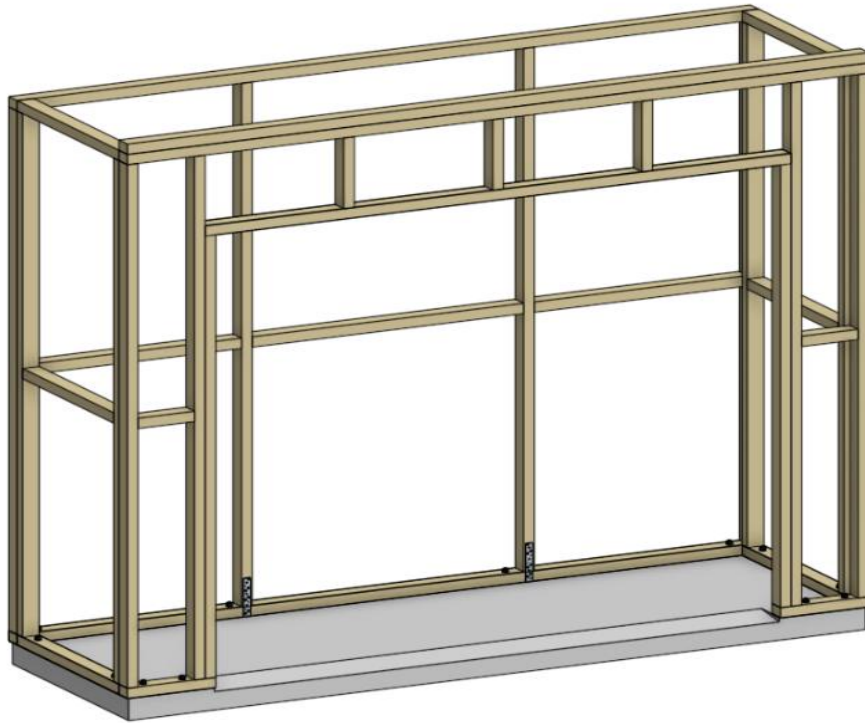

There are now just a few items to finish the timber wall framing ready for cladding installation:

FRAME FLASHINGS

- **Components**

- **F04** Door Head Flashing.
Length is equal to door opening width of 2400mm

- **H03** 2.5 x 30mm fixing clouts.

- **Fix Door Head Flashing**

- Fit the door head flashing to the underside and outer face of the Lintel as shown.

- Use 4 x **H03** fixing clouts into the face of the Lintel and 4 x to the underside.

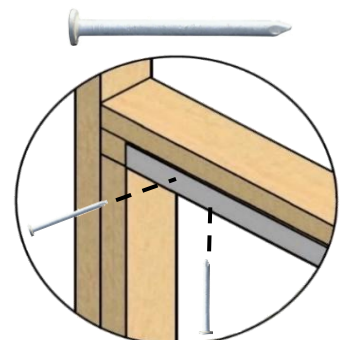
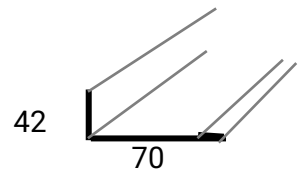

DPC TO STUDS

- **Components**

- H03 2.5 x 30mm fixing clouts.
- A06 DPC roll.



- **Cut Bottom Plate**

- Use a hand saw to cut and remove the bottom plate between door studs.

- **Cut DPC Strips**

- Cut DPC strips for each corner of the shed. DPC should be level with top of top plate and 20mm below bottom of bottom plate.
- Cut DPC strips for each side of each door opening. DPC should be level with bottom of lintel and 20mm below bottom of bottom plate.

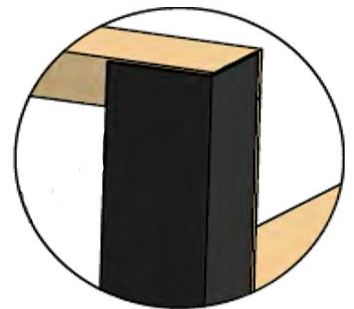

- **Fix DPC to Studs**

- Fold each strip longitudinally down its centre to form a right angle.
- Using ten 30mm clouts per strip, attach DPC strips to each corner and door studs as shown.

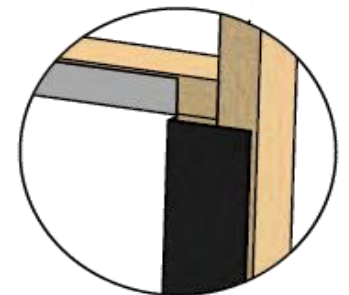

BUILDING PAPER

- Building paper is not supplied as standard for Lifestyle sheds, however if you wish to fit building paper to the walls, do so now.
- First ensure the wall frames are square. Use packaging timber (or similar) as bracing and nail to inside of frame to temporarily hold wall panel square.
- Building paper should be stapled to the outside of the timber framing before the cladding is installed.
- Remove any temporary bracing after cladding is fitted.

- **Fastenings**
 - Use **H05** Wall Cladding screws, 25mm long 
- **Fastener Pattern**
 - External edges: use **H05** screws through every 2nd trough.
 - Internal studs: use 2 x **H05** Screws per sheet, per stud.
 - Top & bottom plate: use **H05** screws at every stud.
- **Fastening the Sheets**
 - Re-check each wall frame for squareness and adjust if necessary.
 - The cladding layout for each wall is shown on the following pages.
 - Fix the top sheet first, it must be flush with the top of the top plate.
 - Tip: Pre-drill the cladding using 3.5mm drill bit for easy fastening.
 - Do not screw off the lower edge of the sheet until the next row of sheeting is in place.
 - Position the second row of sheets. Slip under the sheet above. Ensure sheet lower edges are at the distance from the top of the wall shown on the wall cladding layouts.
 - Some sheets will need to overlap by more than one rib.
 - Finish screwing off the sheet above, and repeat the process for the next lower row.
 - The lower edge of the bottom sheets will be about 30mm below the bottom plate.

IMPORTANT: Always ensure metal swarf has been removed from the cladding surface, from between sheets, and from under the heads of fasteners.

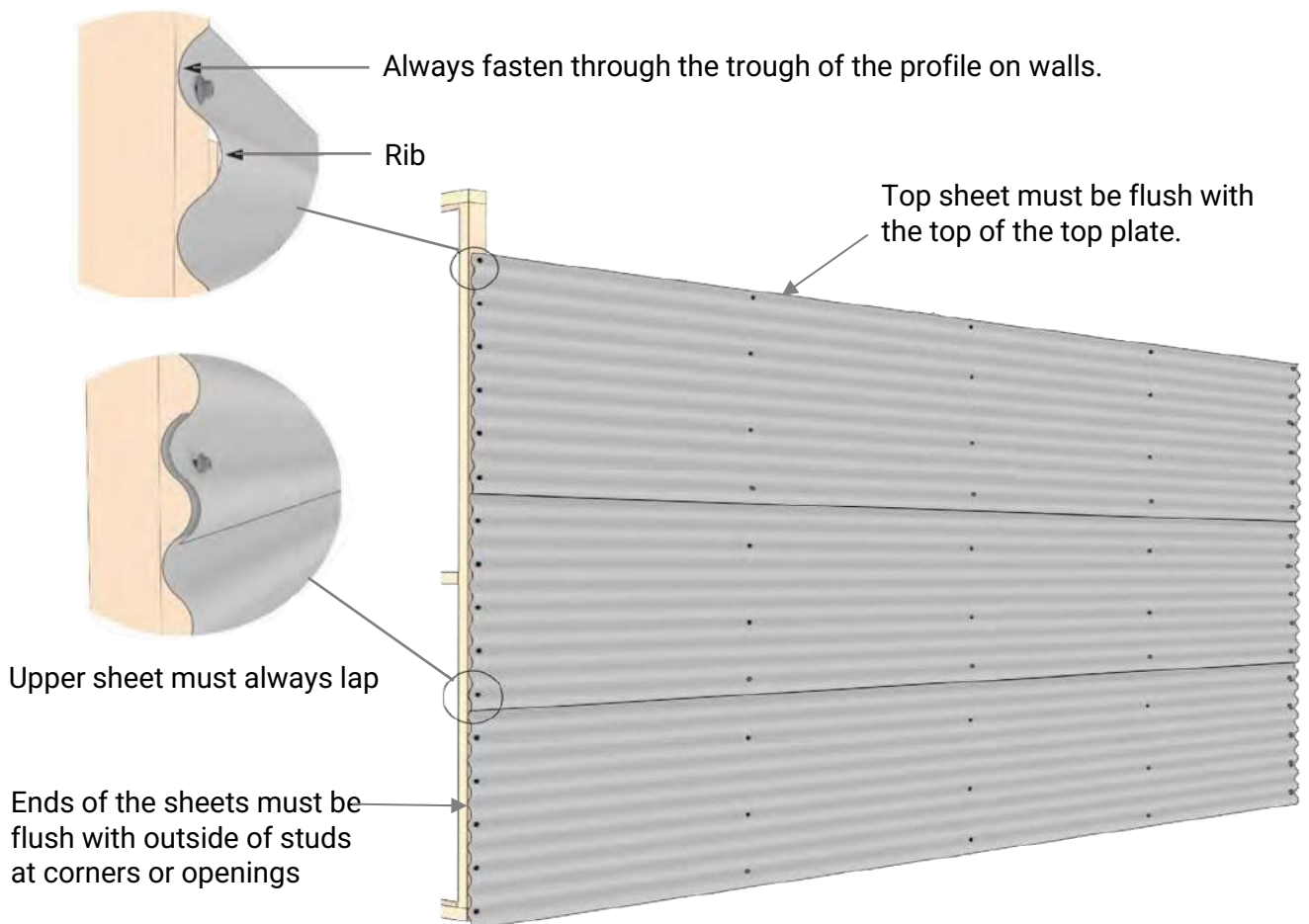

FRONT WALL CLADDING LAYOUT

- Refer to **Section 3.2** for Cladding sheet sizes, using the references given in **blue** below.
- Refer to **Section 6.1** for general instructions on cladding installation.
- Vertical Dimensions are to the visible bottom edges of the sheets.
- Cladding top starts at the top of the top plate, not the packer.

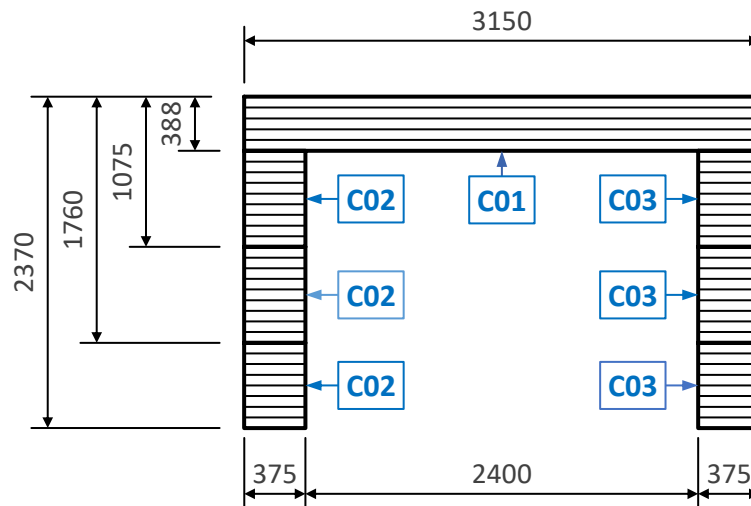

BACK WALL CLADDING LAYOUT

- Refer to **Section 3.2** for Cladding sheet sizes, using the references given in **blue** below.
- Refer to **Section 6.1** for general instructions on cladding installation.
- Vertical Dimensions are to the visible bottom edges of the sheets
- Cladding top starts at the top of the top plate, not the packer.

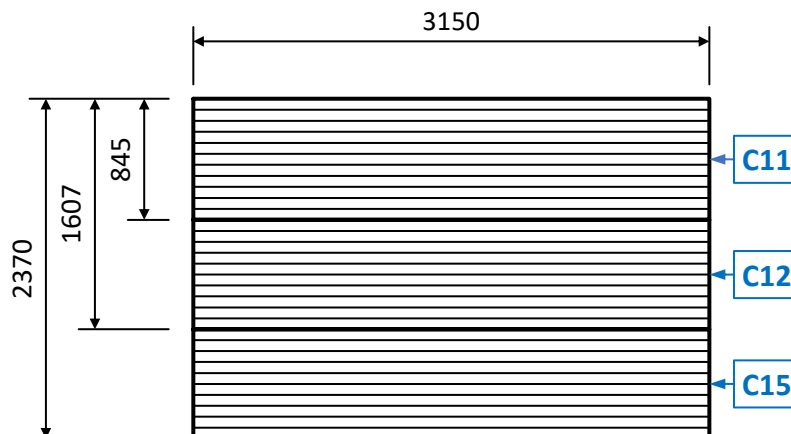

LEFT WALL CLADDING LAYOUT

- Refer to **Section 3.2** for Cladding sheet sizes, using the references given in **blue** below.
- Refer to **Section 6.1** for general instructions on cladding installation.
- Vertical Dimensions are to the visible bottom edges of the sheets

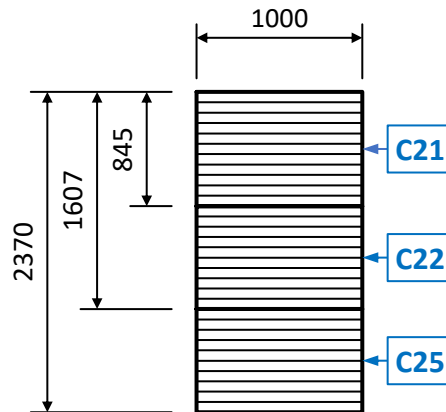

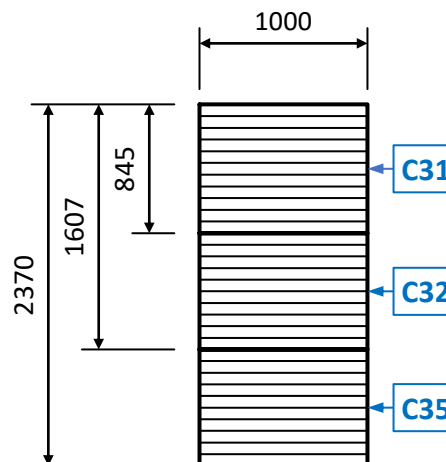

RIGHT WALL CLADDING LAYOUT

- Refer to **Section 3.2** for Cladding sheet sizes, using the references given in **blue** below.
- Refer to **Section 6.1** for general instructions on cladding installation.
- Vertical Dimensions are to the visible bottom edges of the sheets.



6.6 Flashings & Gutter Attachment

• **Components**

- Two **F01** Front Corner Flashings 2365mm long →
- Two **F11** Back Corner Flashings 2365mm long (both have the same profile) →
- **F03** Door Top Flashing 2600mm long →
- **F05** Door Jamb Flashing 1970mm long →
- **F22** Gutter Flashing 3265 mm long →
- **H03** 2.5 x 30mm fixing clouts 
- **H06** Roofing Screws, 55mm long 
- **H07** Rivets 

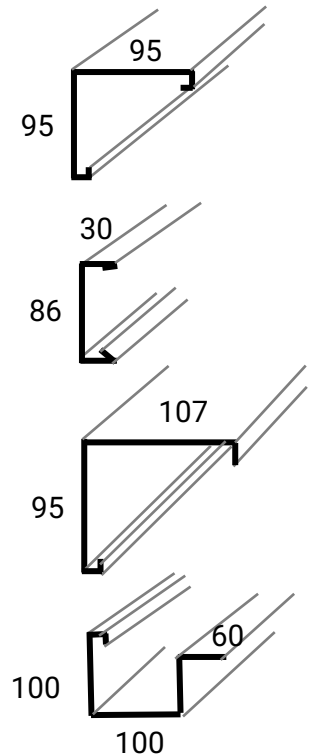

• **Attach Corner Flashings**

- Position **F01** and **F11** corner flashings over corners, ensuring they are square and parallel with wall panels and bottom of flashings are level with bottom of cladding.

- Fix with six **H06** Screws per flashing, spaced evenly over flashing height. Ensure screws pass through a rib of the cladding.

• **Attach Roller Door Flashings**

- Place **F05** Door Jamb flashings so tops are level with under side of lintel. Notch lower end of flashing around the base.

- Nail **F05** Door Jamb flashing to inside of stud using three **H03** clouts and screw into stud through wall cladding using three **H06** Screws passing through a rib of the cladding.

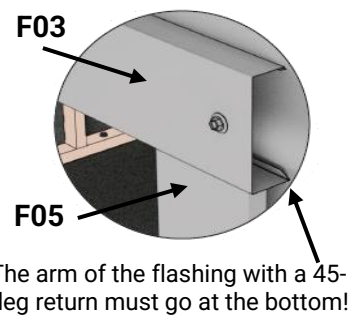

- Sit **F03** Door Top flashing on top of the Door Jamb flashings and centralize. It will protrude about 10mm past the jamb flashings. Fix to lintel centrally on the 86mm face, using four **H06** screws; 1 each end and 2 spaced equally between.

• **Attach Gutter**

- For an outlet, use tins snips to cut two 50mm snips in each end of spouting as shown. Bend the tab between the snips upwards until it is 90° to the base of the spouting.

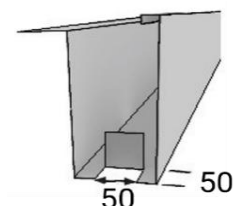

- Centralise Gutter on top of back wall (or front wall if roof slopes to the front). Gutter will overhang corner flashings ~25mm. Fix with 4x **H03** clouts to top of wall.

7.1 Roof Installation

Components

- **H06** Roofing Screws, 55mm long
- **H13** Dome Washers for Clear sheets
- **H07** Rivets
- **H15** 2.8 x 50mm fixing clouts
- **F27** Gutter Strap

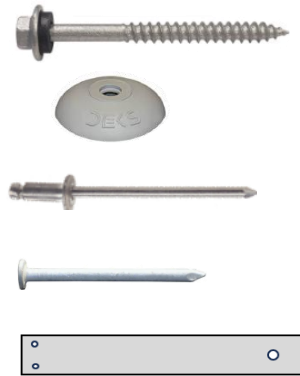

Sheet Fastening

- Position the first roof sheet into position, ensuring the sheet will correctly overlap the next sheet. Set the long edge of the sheet 10mm in from the outside of the timber wall frame.
- Position the sheet to extend 15mm past the outside of the framing at its upper end. Its lower end should overlap the gutter. Use an **H06** screw through a crest of the corrugate profile, to secure the sheet to the wall plate at the *lower* end of the sheet.
- Use an **H15** clout, predrill and nail the sheet through a crest of the corrugate profile, to the wall plate at the *upper* end of the sheet (this will later be covered by the ridge flashing).
- Position each remaining roof sheet, and secure using just *one* **H06** screw at the lower end, and *one* **H15** clout at the upper end, until all sheets are in place. The outer edge of the last sheet should be about 10mm in from the outside of the wall frame.

- Check walls are straight and the framing is square, and all sheets are in the correct position. Now fully secure all roof sheets so that there are four **H06** screws and four **H15** clouts per sheet, in the pattern shown below:



Clear Roof Panels

- If there is a **C42** Clear Roof Panel, position where required, but not on the sides of the roof. **Clear Sheets must sit over steel sheets on both sides:**



- Screws on any **C42** Clear sheets must be fitted with **H13** Dome Washers, after first removing the standard washers that come fitted to the screws.



Gutter Straps

- Space **F27** Gutter Strap(s) evenly along the Gutter length, with the colour side up.
- Rivet each strap with two **H07** Rivets to the top lip of the Gutter, and to the wall top plate through the roofing with one **H06** screw placed centrally on a rib.

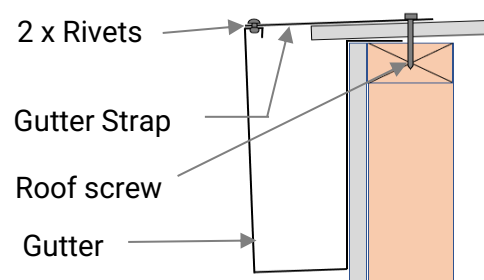

- Components**

- **F23** Ridge Flashing 3265mm long
With Soft Edge on 80mm side

- 2 x **F24** Barge Flashing. 1188 mm long

- **H06** Roofing Screws, 55mm long



- **H05** Wall Cladding screws, 25mm



- **H07** Rivets

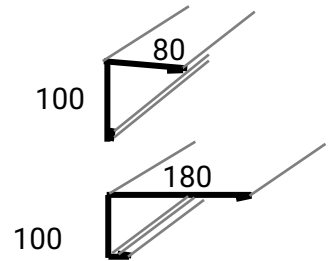

- Attach Ridge Flashing**

- Position **F23** Ridge Flashing on upper end of roof. The flashing arm with a 'soft edge' sits over the roofing. The ends will extend about 20 mm beyond corner flashings.

- Rivet to roof sheet ribs with 3x **H07** rivets per sheet. Rivet to corner flashings with 2x rivets each. Push soft edge down into roof corrugations to prevent water ingress.

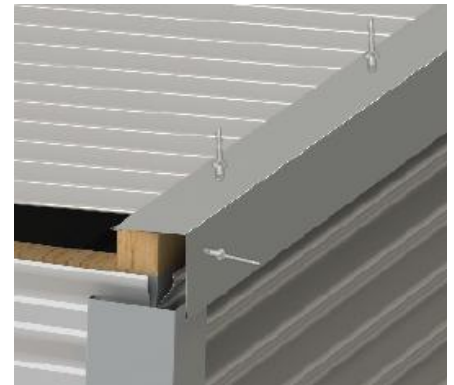

- Install Barge Flashings**

- Position **F24** barges as shown, using 6x **H07** rivets, rivet barge to ridge and spouting. Using **H06** screws, fasten the barges through the roof sheets to the front and back top plate.

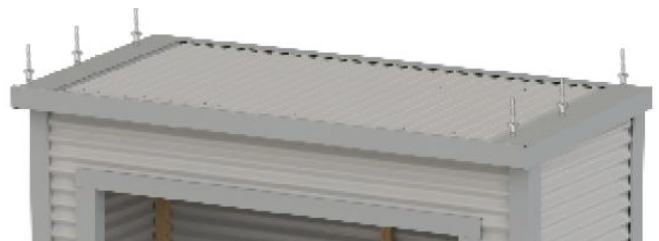

- Rivet underside of barge to underside of Gutter.

- Using tinsnips, cut the side of the **F24** Barge flashing flush with the **F23** Ridge flashing to form a neat corner joint.

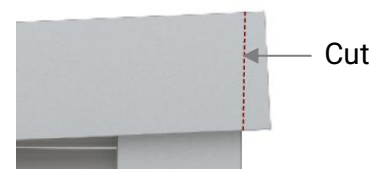

- Clean-up**

- Remove all swarf (drill filings) with a soft brush or rag.
- Hose down roof and walls thoroughly.
- For coloured sheds, use touch-up paint provided on all rivets and exposed cuts.

Scan this QR code to watch a video on roller door installation:

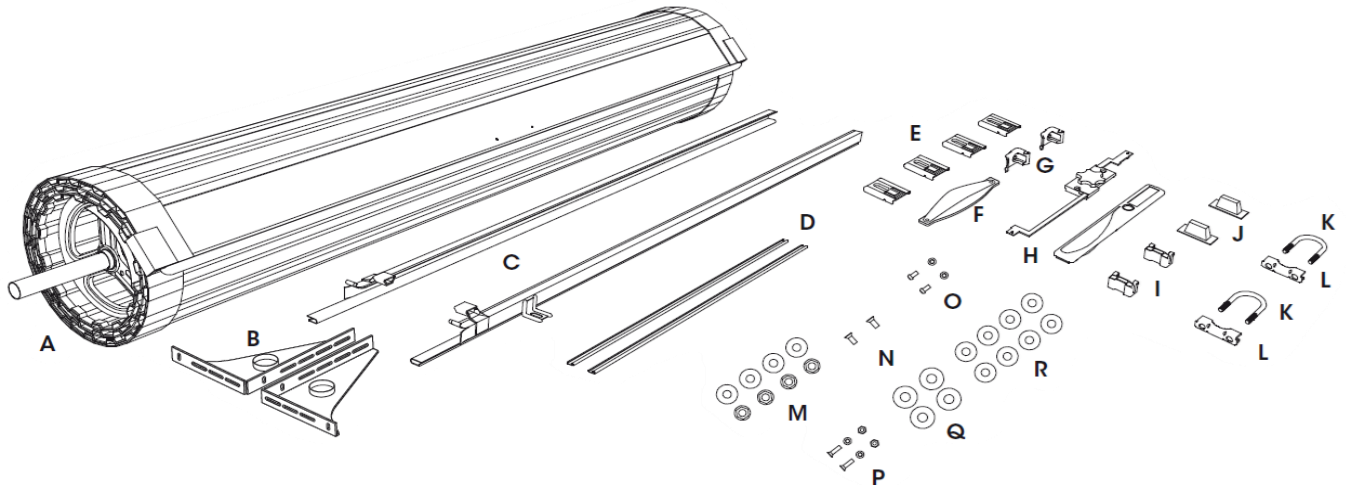

Series 1 Roll-A-Door Parts List		
Item	Description	Quantity
A	Rolled plastic wrapped door	1
B	"A" Style brackets, left and right hand	2
C	Doors guides, left and right handed	2
D	Steel locking bars	2
Small parts bag		
E	Guide clips (Qty is door size dependent)	4 - 10
F	Door handle and fixing to suit	1
G	Bottom rail stops and 6mm screws	2
H	Faceplate and fixing to suit	1
I	Locking bar retainer	2
J	Locking bar covers	2
K	U-Bolts	2
L	Axle / Bracket saddles	2
M	8mm Nuts for U-bolts	4
N	Counter sunk screws for lock and facia	2
O	7mm x 4mm Mushroom head screws for locking bar	2
P	4mm x 6mm Screws for handle	2
Q	10mm Washers	4
R	8mm Washers (Qty is door size dependent)	8 - 12
S	Plastic Clamp	1
T	14g x 50mm Coach screws	18

Also prepare a 400mm long wooden chock, with one end mitred as shown, as an installation aid:



- **Preliminary**
 - **Ensure the Door opening is SQUARE and LEVEL!**
 - Measure the opening width.
 - Measure the door curtain width.
 - Calculate overlap for each side: $(\text{Door width} - \text{Opening width}) \div 2 = \text{Overlap}$
 - Mark the line for the edge of door curtain (overlap) on each side of the opening.
 - **CAUTION: Do not cut the door plastic wrap or packaging yet!**

- **Install Brackets**

- Position bracket (B) centre on outer stud, approximately 140mm up from bottom of lintel and 80mm from inside of door opening to outside of bracket.

- Mark 2 hole positions using the bracket's top and bottom

- Drill both holes, then attach bracket using 14gx50mm coach screws and 10mm washers.

- Install second bracket as above and make sure it is **exactly level with the first bracket.**

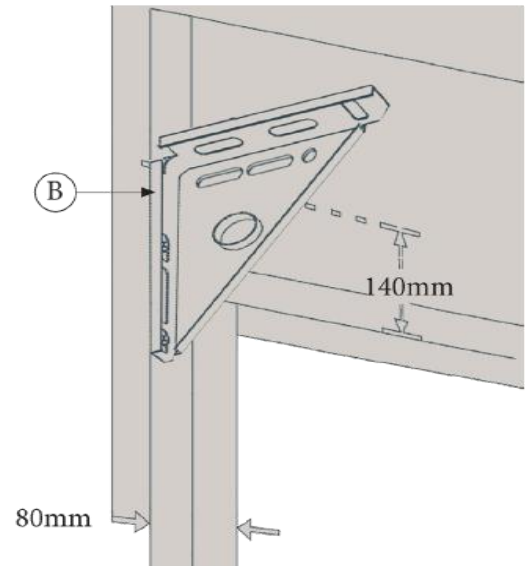

- **Placing Door on Brackets**

- Make sure the axle is free and centred. Centre will be found by rotating the axle a quarter turn in either direction then releasing. With centre found, make a clear mark on the axle against the hub for later reference.

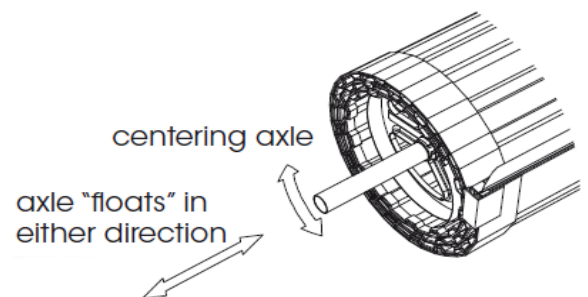

- Using 2 persons and correct lifting techniques, lift door onto brackets (right way around, so door will roll down from the front of the opening).

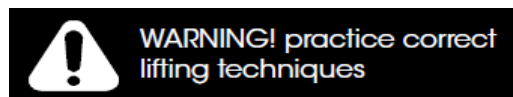

- Immediately loosely fit "U" bolts (K), saddles (L), washers and nuts (M) to the brackets in position shown. Fitting "U" bolts eliminates the door falling from the brackets. (Do not tighten yet.)

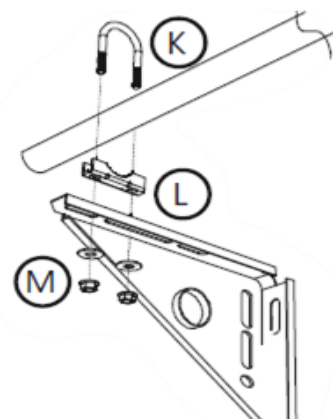

Note: When correctly positioned, the roll may come down a little lower than the underside of the lintel. However it should not come down lower than the bottom of the curtain when fully opened.

8.3 Door Placement

- **Placing Door on Brackets**

- Centre the door with the opening, while ensuring the floating axle is also centred with the door. Do this by lining up previous marks with the hub, then lift both the axle and the door together until it is centred with the opening.

- Rotate the curtain and axle so that the bottom rail of the door is positioned as shown at 3 o'clock.

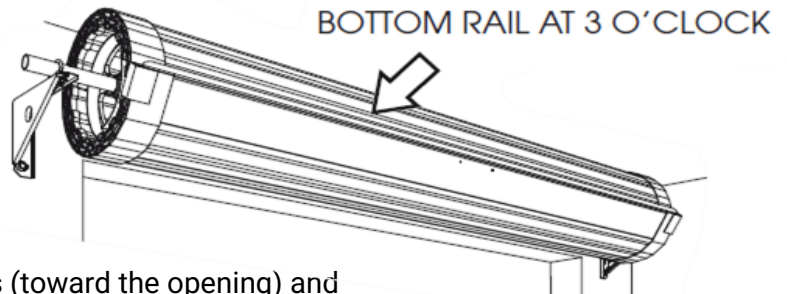

- Push the axle forward in the slots (toward the opening) and tighten the nuts firmly without overtightening.

- **Tensioning the Springs**

- Ensure that the bottom rail is at the 3 o'clock position as shown in previous step

- Ensure both "U" bolts are tightened, then:

- Rotate the door 1½ turns in a forward direction to apply tension. Do not let go as the springs are now tensioned. See arrow in diagram:

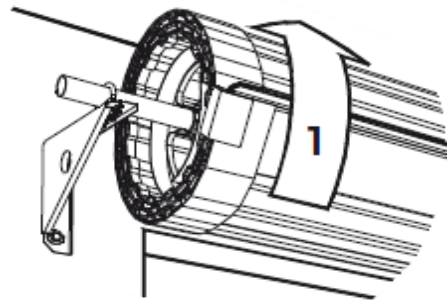

- Hold the door firmly, NOW cut the plastic wrap along the bottom rail (taking care not to damage door surface or weatherseal).

- Pull the curtain down slowly and carefully; position the wooden chock as shown. Take care not to damage door surface. The chock will help hold the door until the guides and stops are fitted.

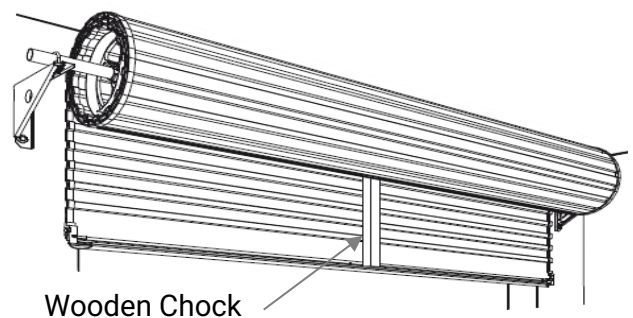

- **Attach Bottom Rail Stops**

- Hook the stop (G) behind lip in rail, as shown

- Secure from underneath the rail with 6mm screws (G) supplied.

- You will need to trim the weatherseal flush with the end of the bottom rail.

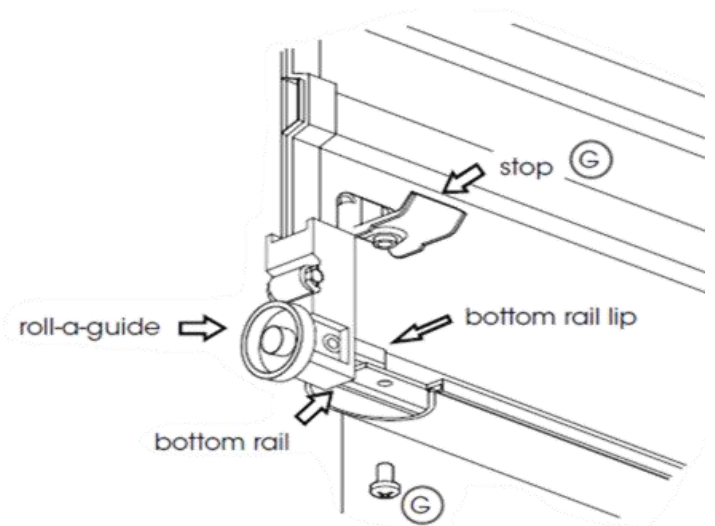

• Installing the Guides

- Ensure curtain overlaps equally on both sides, and cut the guides the correct length (top of guides is level with top of the brackets while the guides bottom is touching the floor).

- Slide two guide clips (E) into each guide (C).
Position bottom clip 200mm from floor with the rest evenly spaced along the guide.

- Position one guide over the edge of the door curtain. Mark and drill the top fixed guide clip and secure it using 14g coach screw and washer, allowing 3mm clearance between inside of guide and plastic roll-a-guide. Ensure guide is plumb, then drill and fix remaining clips. Repeat with second guide.

- Remove the wooden chock and slowly lower the door, removing the plastic wrap as you pull the door down. Reposition the guides as necessary to allow smooth and even operation with 0 - 1mm clearance.

- Ensure door curtain enters guides smoothly. It will be necessary to adjust the guide lead in to achieve this.

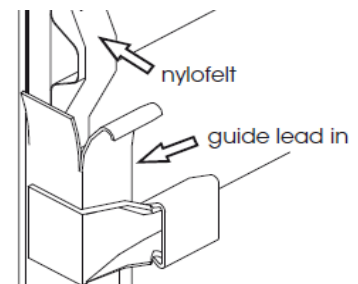
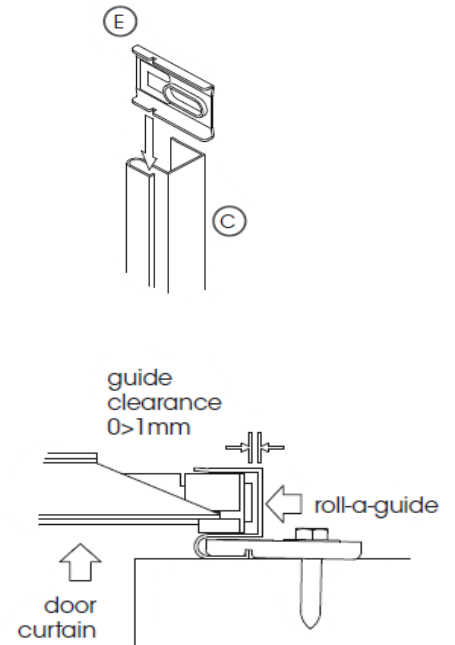

• Fitting Handle

- Fit handle (F) to the outside of the door using the supplied screws (P), nuts, and washers.

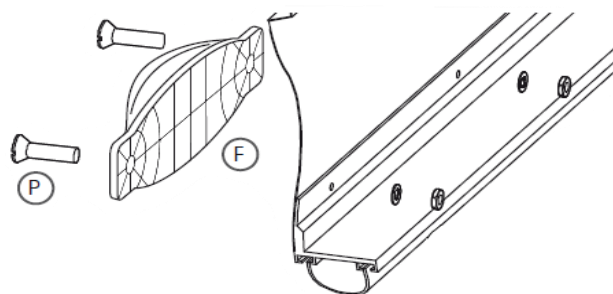

8.5 Fitting Centre Lift Lock

Fendalton - 1BBB

STANDARD

CAUTION: Wear appropriate gloves as some edges of the door are very sharp!

- Raise the curtain until the lock corrugation is visible above door guides.

- Install locking bar retainer (I) in line with lock corrugation by pushing retainer towards door edge, sliding the legs under the Nylofelt® and hooking them over the curtain edge. Ensure lock bar retainers sit squarely on door curtain.

- Fit faceplate (H) to outside of door, where the hook will latch onto curtain edge. Then, slide the faceplate as far to the right as possible. Use adhesive tape on outside to hold in position.

- Attach the lock body (H) to the faceplate from the inside, using the mounting screws and washers. Do not overtighten the screws.

- With the door in the closed position, slide the end of the locking bars (D) through the locking bar retainers, and while holding the bars level, mark the side of the guides.

- Drill and file out a rectangular slot in the guide, no longer than 25mm or wider than 10mm, ensuring top of the slot remains in line with top of the locking bar.

- Slide bars through the guide slot, then back onto locking arms.

- Screw on securely using the countersunk screws (O). Ensure locking bars do not protrude more than 20mm beyond guide when engaged in locked position. It may be necessary to adjust the length of the bars.

- Ensure the guide is clean and dry using a clean rag. Peel lining from adhesive tape on lock bar cover (J) and position over hole. Ensure locking bars move freely.

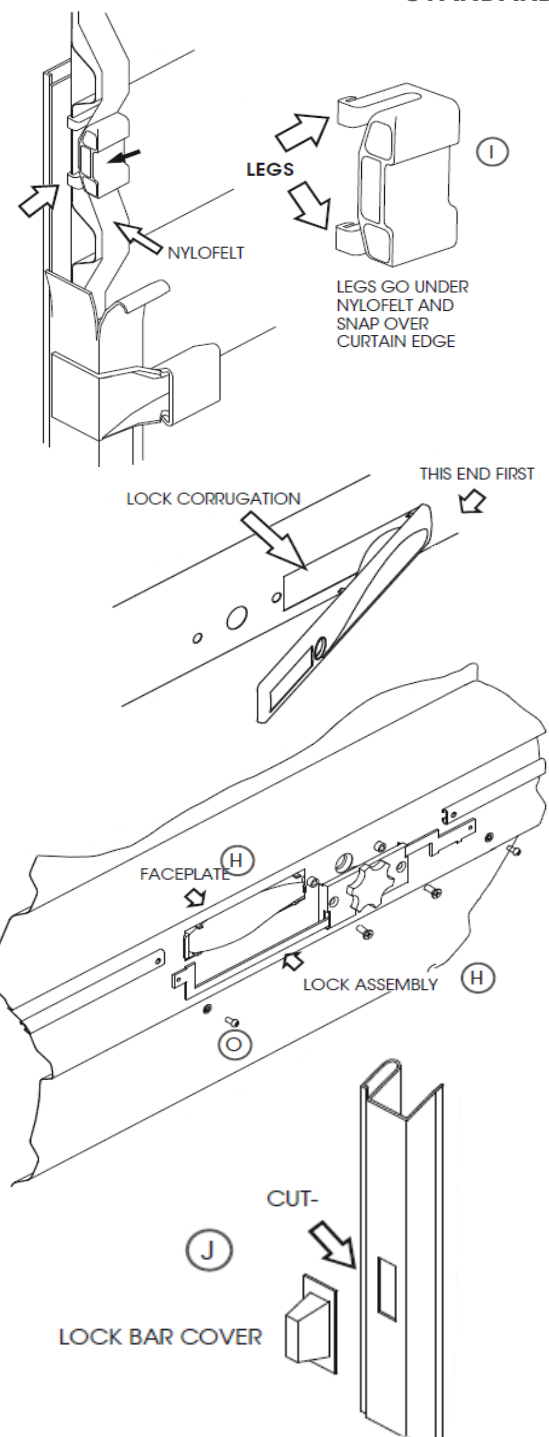

Lock Bar Cover must be installed to prevent finger

LOCK BAR COVER

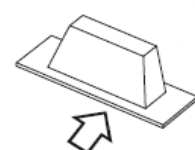

DOUBLE SIDED ADHESIVE TAPE

- **Troubleshooting Guide**

Symptom	Possible Cause	Remedy
Door is hard to operate in BOTH directions	Door is jamming in the guides	a) Check Guide Clearances
		b) Check Guides are plumb
		c) Check guide surfaces are clean and free from oil
		d) Check locking bars are correct length
		e) Check weatherseal is correct length
The door is hard to operate in ONE direction	Spring tension requires adjustment	a) If door is hard to lift, but tends to drop, refer to 'Adjusting Spring Tension' below to increase spring tension.
		b) If door is hard to close, but tends to rise, refer to 'Adjusting Spring Tension' below to decrease spring tension.
The door rolls up crooked	Brackets are not level	Make sure brackets are level.
	Guides are not plumb	Make sure the guides are plumb.
	Axle is not centred	Refer to section 'Centralise the axle when Door is mounted' below.

- **Centralise the Axle when Door is mounted**

WARNING! Ensure that pipe wrench is fitted correctly to the axle and if it is gripped onto the axle, do not underestimate the tension in the spring when undoing the clamps.

CAUTION: THIS ADJUSTMENT REQUIRES 2 PERSONS TO COMPLETE.

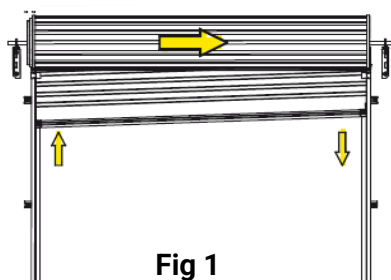

Fig 1

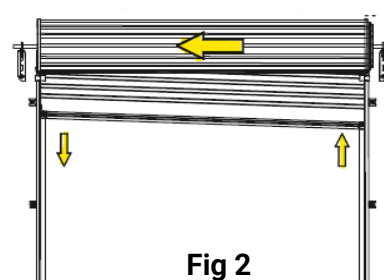

Fig 2

- If the door rolls up crooked with one side higher than the other, proceed as follows:
- Roll the door up as high as possible and tie two ropes around the door roll approximately 300mm from each end, as a safety precaution.
- With a person at each end of the door, hold the axle firmly with a large pipe wrench (Stillson) at least 450mm long.
- Loosen the "U" bolt nuts at both ends and **KEEP A FIRM GRIP ON WRENCH.**
- If the door rolls up crooked with the RIGHT HAND SIDE higher than the left, move the axle 20 - 40mm to the RIGHT, as per Fig 1 above.
- If the door rolls up crooked with the LEFT HAND SIDE higher than the right, move the axle 20 - 40mm to the LEFT, as per Fig 2 above.
- Re-tighten "U" bolts before releasing pipe wrench.
- Test and repeat if further adjustment is needed.
- If the door is stiff to work or rattles over lead-in on top of guide, refer to next section.

- **Adjusting Spring Tension**

WARNING! Ensure that pipe wrench is fitted correctly to the axle and if it is gripped onto the axle do not underestimate the tension in the spring when undoing the clamps.

CAUTION: THIS ADJUSTMENT REQUIRES 2 PERSONS TO COMPLETE.

- Roll the door up as high as possible and tie two ropes around the door roll approximately 300mm from each end, as a safety precaution.
- With a person at each end of the door, hold the axle firmly with a large pipe wrench (Stillson) at least 450mm long.
- Loosen the "U" bolt nuts at both ends and **KEEP A FIRM GRIP ON WRENCH.**
- Rotate the axle in the required direction (see diagram).
- Re-tighten the "U" bolts **BEFORE** releasing pipe wrench.
- Test and repeat if further adjustment is necessary.

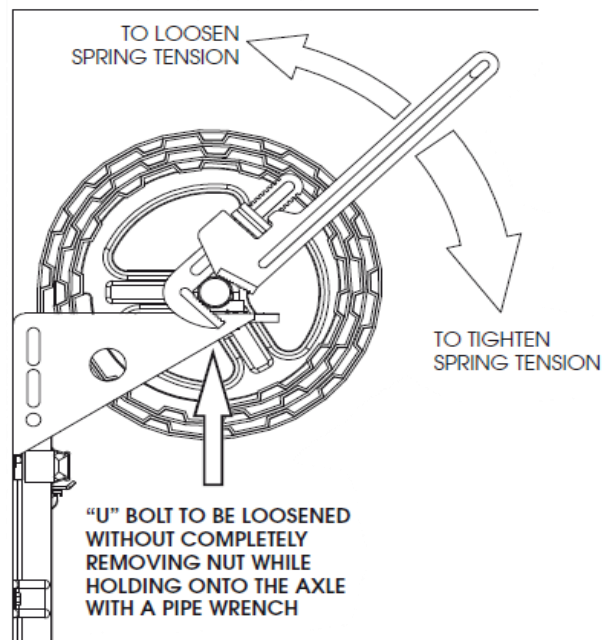

If you need professional assistance to install or remedy the roller door, please call your nearest Garador or Dominator Garage door dealer as listed on these web pages:



1. Duratuf warrants that their Lifestyle sheds will be free from manufacturing defects for **30 years**. This warranty also covers components which are missing or damaged at time of despatch from the factory.
2. Duratuf warrants the durability of the structural framing for **30 years**.
3. Duratuf warrants that the metal roofing and wall cladding will not perforate due to corrosion within the following periods:
 - Standard Non-Coastal Warranty – **30 years** if located greater than 2,000m from saltwater, or **15 years** if located between 1,000m and 2,000m from saltwater.
 - With Coastal Upgrade Option – **30 years** if located greater than 1,000m from saltwater, or **15 years** if located between 250m and 1,000m from saltwater.

WARRANTY TERMS AND CONDITIONS

- The warranty is not transferrable and only valid for the original purchaser. Proof of purchase and proof of damage or defect is required to submit a claim. Warranty periods begin at the date of manufacture.
- This warranty is in addition to your rights under New Zealand consumer law and must be registered within 90 days from purchase to be valid. Refer to the warranty registration guidance below. All claims must be made in writing within 30 days of discovery. Interference with the product or other action taken to remedy a defect prior to Duratuf being notified of the suspected defect and Duratuf being given a reasonable time to inspect the product in situ will invalidate a claim.
- For the warranty to be valid, the recommendations in our **Kitset Care Guide** <https://www.duratuf.co.nz/kitset-care-guide/> and the **Assembly Care Instructions** given in the Assembly Instruction booklet must be followed; and the **Minimum Maintenance** in accordance with instructions below must be performed for the life of the product.
- Except as provided otherwise by NZ law, the liability of Duratuf is limited to replacing or repairing any defective or missing product. Any repaired or replaced material will be covered only by the balance of the original warranty period. Duratuf will not be liable for any consequential loss or damage, or labour costs. Transport charges will apply to our nearest reseller only.
- The structural framing and cladding warranties are subject to the shed being installed on a level concrete base, or other solid supports, at least 40mm above ground level, and contact being prevented at all times with soil, vegetation, organic matter, fertilizers, or other moisture retaining substances.
- In the rare event of a claim and upon receiving proof of purchase and defect, Duratuf will at its option repair or replace defective parts, or provide a prorated refund for the remaining life of the applicable warranty. Any replacement product provided will be covered by the Warranty for the balance of the Warranty term as if the replaced product were original product.
- Duratuf reserves the right to inspect the shed in situ at the installation site and to conduct tests at any time after a Warranty claim is received. Any interference with the shed prior to inspection by Duratuf may void a claim under this Warranty.
- Any product replaced under this Warranty becomes the property of Duratuf.
- Any failure, delay, or indulgence by Duratuf will not operate as a waiver. A waiver by Duratuf of any condition of this Warranty is not a waiver of any other condition. No waiver is effective unless it is in writing.
- All terms, conditions, warranties, undertakings, inducements, and representations other than contained in this warranty, whether express or implied, statutory, or otherwise, are expressly excluded.
- This Warranty does not exclude, restrict, or modify any liability that cannot be excluded, restricted, or modified at law.

EXCLUSIONS FROM WARRANTY COVER

- Normal wear and tear. Fading, chalking, or discolouration of the cladding. Minor white corrosion at cuts or bends.
- Cladding perforation in areas where severe or very severe environmental situations are extended inland by local conditions.
- Timber floors, where used for storage of other than normal lightweight household items.
- This warranty will not apply if the failure or defect is caused or contributed to by an event or action beyond the reasonable control of Duratuf, including without limitation:
 - Any modification of the shed structure or cladding different from the design provided in the assembly instructions.
 - Mechanical, chemical, or other damage sustained after despatch from Duratuf's factory.
 - Problems resulting from misuse or use for purposes other than normal dry storage use.
 - Fire, flood, storm, cyclone, earthquake or other 'Acts of God.'

MINIMUM MAINTENANCE REQUIREMENTS

- All metal swarf must be cleaned off the shed IMMEDIATELY.
- Wash all external surfaces using a soft nylon brush with water every 12 months, or for locations within 2 km of saltwater, wash every 3 months. After a storm, wash the cladding and the gutters as soon as possible to remove any salt deposits.
- A low-pressure water spray may also be used, less than 10 MPa (1500 psi or 100 Bar).
- Outdoor cleaning detergents may be used if they do not contain bleach, chlorine, or other harmful chemicals.
- Volcanic ash fallout and pollen deposits—wash as soon as possible, removing all deposits from roof and gutters.
- Gutters and channels to be kept clear of leaves and dirt at all times.
- Remove any lichen or mould: First wash off any loose growth with a brush and water. Apply diluted bleach (sodium hypochlorite) at 2% solution. A small amount of household detergent (no more than 5-7 ml per litre of water) may be added to the solution to improve wetting. Leave for 5 minutes. Wash down with copious amounts of clean water.
- Remove and replace any fasteners, washers, or fittings showing signs of corrosion.

WARRANTY REGISTRATION

Go to <https://duratuf.co.nz/warranty> to register the Warranty within 90 days of purchase. Alternatively, call us on **0800 438 274**. It is important to keep your proof of purchase as it will be required in the unlikely event of a claim.

Thank you for investing in a Duratuf Lifestyle Range Shed.
We are sure that it will provide excellent long-term storage and add value to your property.

To continually improve our products and service, we would love to hear about your Duratuf experience and why you chose us.
Please scan the below QR code to fill out the survey. Thank you for your feedback!

