



Windsor
Assembly Instructions
1BBB

STANDARD



Kitset Care Guide



www.duratuf.co.nz/lifestyle

| | |
|-------------|-----------------|
| Ref: | STANDARD |
| Frame size: | 2400W x 1500D |
| Model: | DLL2415 |
| Variant: | 1BBB |

Template Version

v3.0 - ST

Section

- 1.0 **Contents**
- Before you start**
- 2.1 Before you start
- 2.2 Required Tools
- Parts Lists**
- 3.1 Timber List
- 3.2 Cladding List
- 3.3 Flashings, Doors, Windows
- 3.4 Hardware List
- Base Specifications**
- 4.1 Concrete Base
- Timber Framing**
- 5.1 Timber Framing - General
- 5.2 Front and Back Walls
- 5.3 Left and Right Walls
- 5.4 Stud Ties and DPC
- 5.5 Wall Frame Installation

- 5.8 Frame Finishing
- Wall Cladding**
- 6.1 Cladding - General
- 6.2 Front and Back Wall Cladding
- 6.3 Left and Right Wall Cladding
- 6.6 Top Plate, Corner, & Door Flashings
- Roof installation**
- 7.1 Gutter Assembly
- 7.2 Roof Installation
- 7.3 Barge Flashing Attachment
- 7.4 Fascia Flashing Attachment
- Roller Door Installation**
- 8.1 Roller Door Parts List
- 8.2 Bracket Installation
- 8.3 Door Placement
- 8.4 Fitting Guides and Handle
- 8.5 Fitting Centre Lift Lock
- 8.6 Door Troubleshooting
- Warranty**
- 9.1 Lifestyle Shed TripleTuf® Warranty

2.1 Before you start

Please read this section carefully before beginning!

Kitset Care Guide

If you are not assembling your shed immediately, please refer to our Kitset Care Guide. You may find it using this QR code:

Kitset Care Guide



General Information

- This shed is not designed to be compliant for habitable use.
- Take note of any regulations regarding shed location in relation to boundaries etc.
- Engineering drawings and producer statements are available on the Duratuf website for those sheds that may require them for Building Consent purposes.
- Exemptions from a requirement for a Building Consents are available in many situations; refer to the information on these web pages:

Single-storey detached buildings not over 10 square metres (floor area inside framing)



Single-storey detached buildings between 10 & 30 square metres (floor area inside framing)



Safety Precautions

- ! Two or more persons or mechanical aids may be required to handle Kitset packages.
- ! Do not attempt to build your shed in windy conditions.
- ! Wear work gloves, and ear and eye protection while assembling.
- ! Be cautious of sharp edges when handling parts.
- ! Use electric tools with care. Always use a Residual Current Device for protection when using mains voltage tools or equipment outdoors.
- ! Ensure safety requirements are met when working with ladders, see:

Safety requirements when working with ladders:



Site Preparation

- The site must be level, with access around all sides of the shed for installation.
- Be aware that sheds under overhanging trees may require additional maintenance to prevent lichen growth and blocked gutters etc.
- A raised concrete slab is the best substrate for a Duratuf Lifestyle shed but must be prepared and poured at least a week before shed assembly.

Warranty Precautions

Your Lifestyle shed is covered by our **Triple Tuf®** Warranty. There are minimum maintenance requirements for your warranty to be valid. For more information, refer to the back page of these instructions, or use these QR codes:

Information:



Warranty Registration:



Assembly Care Instructions





The following warranty requirements must be carefully observed during installation:

- The shed must be installed on a level concrete base, or other solid supports, at least 40mm above ground level.
- Prevent contact between shed cladding and components with soil, vegetation, organic matter, fertilizers, or other chemicals or moisture retaining substances at all times. Prevent contact with cement or wet concrete.
- All metal swarf must be cleaned off the shed IMMEDIATELY as it will quickly initiate corrosion. This includes swarf trapped between steel sheets.
- Do not mark cladding with a graphite pencil, as this may initiate corrosion.
- Do not allow the slightest trace of sunscreen to come into contact with coloured cladding as it will cause discolouration over time. Always use gloves when handling steel.

Preparing to assemble

- Please read all instructions carefully before beginning!
- All dimensions are in millimetres.
- Ensure you have all the tools required, refer to the list on the following page.
- Check all the parts shown in the Parts Lists in Section 3 are included in your kitset and have not been damaged during transit. If replacement parts are required, please notify Duratuf before commencing assembly.
- Two persons are required for safe shed assembly.
- Remove the protective film from all flashings and coloured steel components prior to installing them.

You will need the following tools which are not supplied with your kitset:

| | | |
|--|--|---|
| <p>Riveter</p>  | <p>Pipe Wrench</p>  <p>For Roller Door installation</p> | <p>Caulking Gun</p>  |
| <p>Tin Snips (LH & RH)</p>  | <p>Hacksaw</p>  | <p>Adjustable Spanner</p>  |
| <p>Flat File</p>  | <p>Hand saw</p>  | <p>Hammer</p>  |
| <p>Utility Knife</p>  | <p>Spirit Level</p>  | <p>Hex Drive Bits</p>  <p>5/16" and 3/8" sizes</p> |
| <p>Drive Bits</p>  <p>Square drive #2</p> | <p>Drill bits</p>  <p>3.5, 7, 8, 10, and 13mm</p> | <p>Masonry Bits</p>  <p>10 and 12mm</p> |
| <p>Tape Measure</p>  | <p>Cordless Drill / Screwdriver</p>  | <p>Ladder</p>  |
| <p>String Line</p>  | <p>Hammer Drill</p>  <p>For concrete bases</p> | |

3.1 Timber List

Windsor - 1BBB

STANDARD

RAFTERS

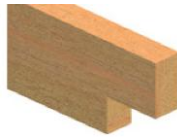

Picked by:

Checked by:

| Ref | Code | Description | Length | Qty | ✓ |
|-----|------|-------------|--------|-----|---|
| | | | | | |
| | | | | | |

TIMBER FRAMING



Picked by:

Checked by:

Total Timber Framing Pieces: 31

| Ref | Code | Description | Length | Qty | ✓ | |
|-----|----------------------------|-------------|-------------------------|------|---|--|
| T01 | Bottom Plate, Front & Back | T3F70-2400 | H3 Framing 70x45 2400mm | 2400 | 2 | |
| T02 | Top Plate, Front & Back | T3F70-2400 | H3 Framing 70x45 2400mm | 2400 | 2 | |
| T04 | Lintel | T3F70-1890 | H3 Framing 70x45 1890mm | 1890 | 2 | |
| T05 | Studs, Front Wall | T3F70-2325 | H3 Framing 70x45 2325mm | 2325 | 4 | |
| T06 | Door Trimming Studs | T3F70-1970 | H3 Framing 70x45 1970mm | 1970 | 2 | |
| T07 | Lintel Jack Studs | T3F70-0265 | H3 Framing 70x45 265mm | 265 | 2 | |
| T08 | Nog, Front (LH) | T3F70-0165 | H3 Framing 70x45 165mm | 165 | 1 | |
| T09 | Nog, Front (RH) | T3F70-0165 | H3 Framing 70x45 165mm | 165 | 1 | |
| T11 | Studs, Back and Sides | T3F70-2250 | H3 Framing 70x45 2250mm | 2250 | 7 | |
| T14 | Nog, Back | T3F70-1132 | H3 Framing 70x45 1132mm | 1132 | 2 | |
| T21 | Bottom Plate, Sides | T3F70-1360 | H3 Framing 70x45 1360mm | 1360 | 2 | |
| T22 | Top Plate, Sides | T3F70-1360 | H3 Framing 70x45 1360mm | 1360 | 2 | |
| T24 | Nog, Side | T3F70-1270 | H3 Framing 70x45 1270mm | 1270 | 2 | |

3.2 Cladding List

Windsor - 1BBB

STANDARD



Picked by: Checked by:

Total No. of Sheets: 19

| Ref | | Code | Description | Length | Qty | ✓ |
|-----|---------------------------|------------|----------------------------------|--------|-----|---|
| C01 | Wall Sheets, Front Top | CCC4-2400H | Corrug Col 0.4 2400mm Half Sheet | 2400 | 1 | |
| C02 | Wall Sheets, Front LH | CCC4-300 | Corrugate Col 0.4 300mm | 300 | 3 | |
| C03 | Wall Sheets, Front RH | CCC4-300 | Corrugate Col 0.4 300mm | 300 | 3 | |
| C11 | Wall Sheets, Back (1) | CCC4-2400 | Corrugate Col 0.4 2400mm | 2400 | 1 | |
| C12 | Wall Sheets, Back (2A) | CCC4-2400 | Corrugate Col 0.4 2400mm | 2400 | 1 | |
| C15 | Wall Sheets, Back (3A) | CCC4-2400 | Corrugate Col 0.4 2400mm | 2400 | 1 | |
| C21 | Wall Sheets, LH Side (1) | CCC4-1500 | Corrugate Col 0.4 1500mm | 1500 | 1 | |
| C22 | Wall Sheets, LH Side (2A) | CCC4-1500 | Corrugate Col 0.4 1500mm | 1500 | 1 | |
| C25 | Wall Sheets, LH Side (3A) | CCC4-1500 | Corrugate Col 0.4 1500mm | 1500 | 1 | |
| C31 | Wall Sheets, RH Side (1) | CCC4-1500 | Corrugate Col 0.4 1500mm | 1500 | 1 | |
| C32 | Wall Sheets, RH Side (2A) | CCC4-1500 | Corrugate Col 0.4 1500mm | 1500 | 1 | |
| C35 | Wall Sheets, RH Side (3A) | CCC4-1500 | Corrugate Col 0.4 1500mm | 1500 | 1 | |
| C41 | Roof Sheets | CCC4-1830 | Corrugate Col 0.40 1830mm | 1830 | 3 | |

3.3 Flashings, Doors, Windows

Windsor - 1BBB

STANDARD

FLASHINGS

Picked by:

Checked by:

Total No. of Flashings: 14

| Ref | Code | Description | Length | Qty | ✓ | |
|-----|-----------------------|--------------|---------------------------------|------|---|--|
| F01 | Front Corner Flashing | FLCC-2440 | Corner Flashing 95x95 2440mm | 2440 | 2 | |
| F02 | Top Plate Flashing | FLCTP-2400 | Top Plate Flashing 60x60 2400mm | 2400 | 1 | |
| F03 | Door Top Flashing | FLCDT-2000 | RD Top Flashing 86x30 2000mm | 2000 | 1 | |
| F04 | Door Head Flashing | FLCDH70-1800 | RD Head Flashing 70mm 1800mm | 1800 | 1 | |
| F05 | Door Jamb Flashing | FLCDJ70-2045 | RD Jamb Flashing 70mm 2045mm | 2045 | 2 | |
| F11 | Back Corner Flashing | FLCC-2365 | Corner Flashing 95x95 2365mm | 2365 | 2 | |
| F21 | Front Fascia | FLCF151-2525 | Fascia 151x90x130 2525mm | 2525 | 1 | |
| F22 | Gutter | FLCG149-2525 | Gutter 149x100x125 2525mm | 2525 | 1 | |
| F24 | Barge Flashing | FLCB150-1895 | Barge Flashing 150x180 1895mm | 1895 | 2 | |
| F27 | Gutter Straps | FLCGS-200 | Gutter Strap Col 200mm | 200 | 1 | |

DOORS AND WINDOWS

Picked by:

Checked by:

| Ref | Code | Description | Length | Qty | ✓ | |
|-----|-------------|-------------|-----------------------------|------|---|--|
| D01 | Roller Door | JRD220-180 | Roller Door 2200 H x 1800 W | 1800 | 1 | |

3.4 Hardware List

Windsor - 1BBB

STANDARD

HARDWARE

Picked by:

Checked by:

| Ref | Code | Description | Length | Qty | ✓ | |
|-----|----------------------|-------------|-------------------------------|-----|-----|--|
| H01 | Framing Screws | XSWCG10-75 | Woodscrew Csk Galv 10g x 75mm | EA | 140 | |
| H02 | Long Framing Screws | XSTHG14-100 | Type 17 Screw Galv 14gx100mm | EA | 16 | |
| H03 | Fixing Clouts | XNCG25-30 | Galv Clout 2.5 x 30mm | EA | 80 | |
| H04 | Bracket Nails | XNCG31-30 | Galv Bracket Nail 3.15 x 30mm | EA | 70 | |
| H05 | Wall Cladding screws | XSRT25N | Cladding Screw with Neo 25mm | EA | 190 | |
| H06 | Roofing Screws | XSRS55N | Roof Screw with Neo 55mm | EA | 50 | |
| H07 | Rivets | XRTC4-3 | Rivet Truss Head Coloured 4-3 | EA | 80 | |

ACCESSORIES

Picked by:

Checked by:

| Ref | Code | Description | Length | Qty | ✓ | |
|-----|----------------------|-------------|---------------------------------|-----|---|--|
| A04 | Stud Ties | HKST-430 | Stud Tie 0.9 x 25 x 430mm strap | EA | 5 | |
| A06 | DPC Strip | HMDP75-30 | Damp Proof Course 75mm x 30m | EA | 1 | |
| A12 | Barge Corner Jointer | FLBCJ | LS Barge Corner Jointer 145mm | EA | 4 | |
| A13 | Gutter End Caps | FLGEC | LS Gutter End Cap (Zinc) | EA | 2 | |
| A14 | Downpipe | ADP080-30 | Downpipe PVC 80mm x 3000mm | EA | 1 | |
| A15 | Downpipe Dropper | ADD080E | Downpipe Dropper PVC 80mm | EA | 1 | |
| A16 | Downpipe Bracket | ADK080 | Downpipe Bracket PVC 80mm | EA | 2 | |
| A21 | Sealant Cartridge | HSR300C | Roofers Silicon Clear 300ml | EA | 1 | |
| A22 | Touchup Paint | HCPV | Paint Vial | EA | 1 | |
| A23 | Touchup Brush | HCPB | Paint Brush | EA | 1 | |

OPTIONAL ITEMS

Picked by:

Checked by:

| Ref | Code | Description | Length | Qty | ✓ |
|-----|-----------------------------|-------------|-----------------------------------|------|---|
| C42 | Clear Roof Panel | CTC24-1830 | Translucent Corrugate 1830mm | 1830 | |
| H13 | Dome Washers for Clearlites | XWD32 | Dome Washer for Clear Roof Sheets | EA | |

Reduce Steel Roof Sheet qty by 1 for every Clear Roof Panel. Add 8 x Dome washers per Clear Roof Panel.

A raised concrete slab is the ideal base for your shed. These instructions are not a complete guide to constructing concrete bases; the services of an experienced builder are recommended. A concrete floor must be prepared and poured at least a week before shed assembly.

- Ground preparation:**
 - Build on 'Good Ground' as defined by NZS3604:2011 'Timber Framed Buildings'.
 - Provide at least 75mm of compacted granular fill under the slab.
 - Place 250-micron polythene DPC between the slab and the substrate.
- Slab dimensions:**
 - Refer to the concrete slab plan for your shed on the following page
 - Slab to be 20mm less in width and length than the shed Frame size
 - 100mm min thick slab with 200x200 thickened edges as per detail
 - Floor to be 100mm minimum above ground level. Use a level or laser to level the slab.
 - Slab sides to be straight, and diagonal dimensions equal, to ensure squareness!



- Slab Specifications:**
 - 20MPa concrete with 665 or SE62 reinforcing mesh with 60mm bottom cover
 - Provide an HD12 continuous perimeter bar with 75mm cover to edge of base

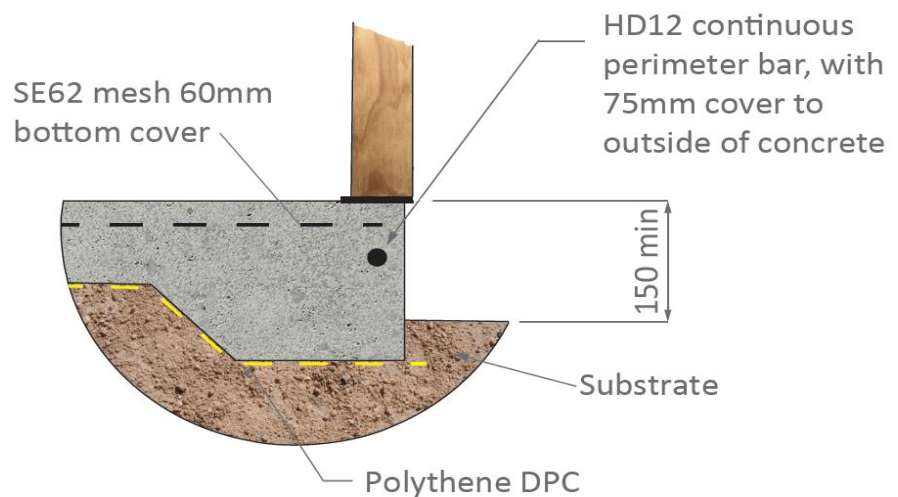

- Door Rebates:**
 - Rebates should be formed in the concrete at doorways to enhance weather proofing
 - Rebates to be the same width as the door, and slope down 20mm over a 150mm depth

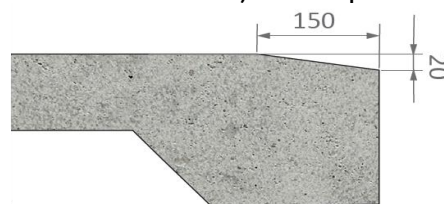

Door Rebate

CONCRETE BASE PLAN

The plan below shows the dimensions for a concrete slab for a Duratuf Lifestyle 'Windsor' shed with door rebate positions for a '1BBB' customization code.

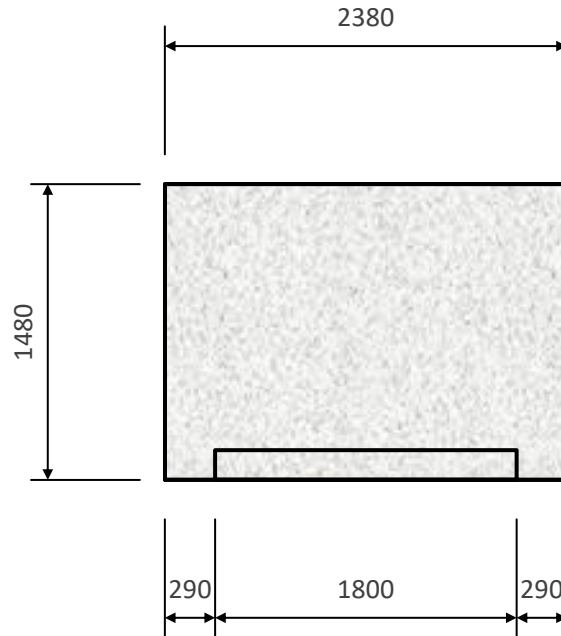

- **Framing Joints**

- Use two **H01** 10g x 75mm countersunk head galvanized screws per joint.



- Fasten studs to plates with two screws through the plates into the stud ends.
- Fasten noggs to studs with two screws skewed through the nog into the stud.

- **Wall Panel Assembly:**

- Assemble each wall frame as a single panel, as shown in **Section 5.2** and **Section 5.3**.
- Each panel is shown as observed from the **OUTSIDE** of the shed.
- Each frame member has a reference linked to the timber list in Section 3.1.
- These are shown as blue characters in a square frame, e.g.-



- **Assembly Sequence:**

- For each wall panel, firstly layout the top and bottom plates on a flat surface.
- Fasten the two outer studs between the top and bottom plates and fasten.
- Position the remaining full-length studs.
- Check the distance between each stud; use the noggs as spacers. Fasten studs to plates.
- Fasten the noggs in place at the correct height.
- End noggs may need to be trimmed due to variations in stud thickness.

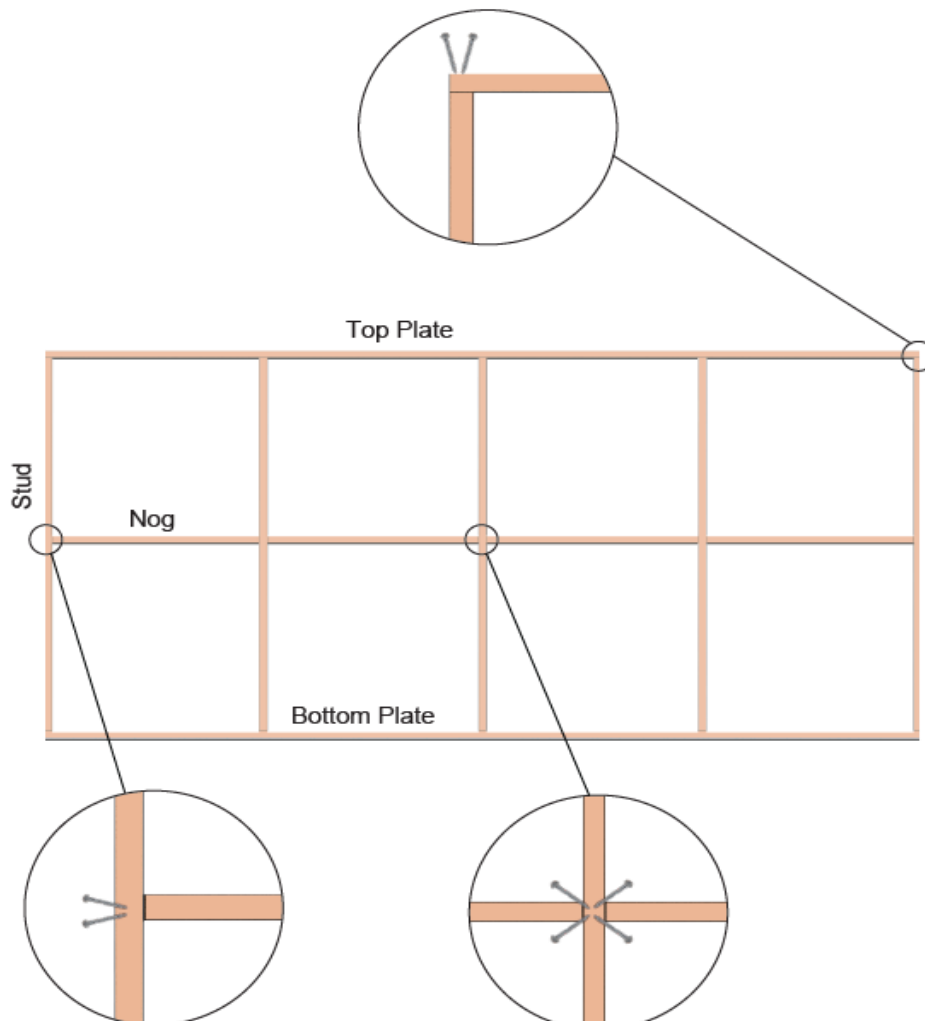

FRONT WALL FRAMING LAYOUT

- Assemble the front wall framing shown below. Do not install any cross bracing yet.
- Refer to **Section 5.1** for general instructions on wall framing assembly.
- There are two lintel members, **T04**, one lies one on top of the other. Screw the Jack studs, **T07**, to the upper lintel member then screw the lower lintel member to it.
- Join each pair of double studs either side of door with 8 x screws at 250mm centres.

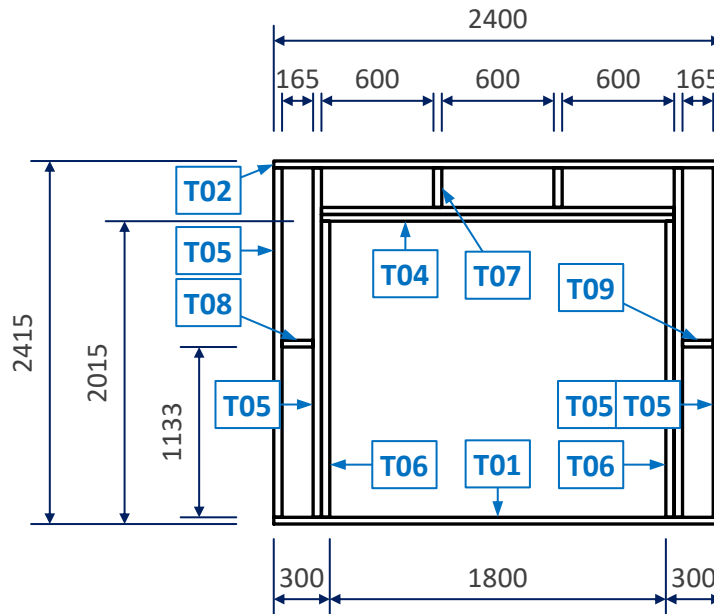
**BACK WALL FRAMING LAYOUT**

- Refer to **Section 5.1** for general instructions on wall framing assembly.

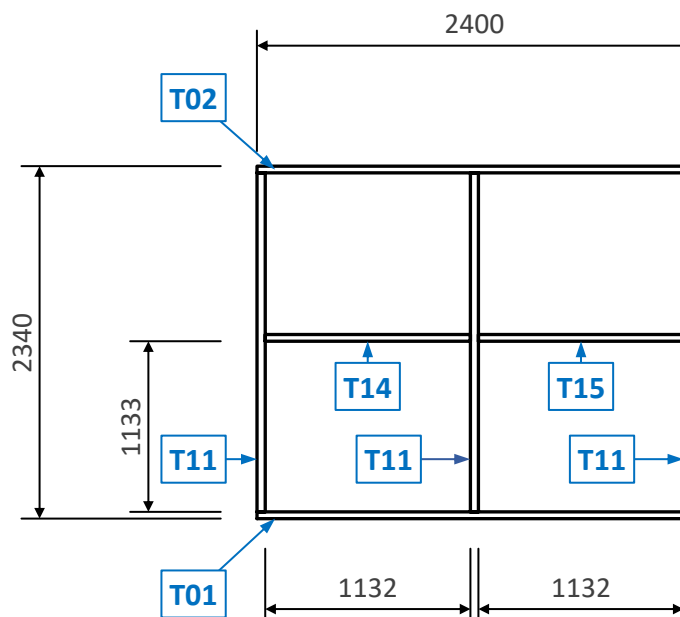

LEFT WALL FRAMING LAYOUT

- Refer to Section 5.1 for general instructions on wall framing assembly.

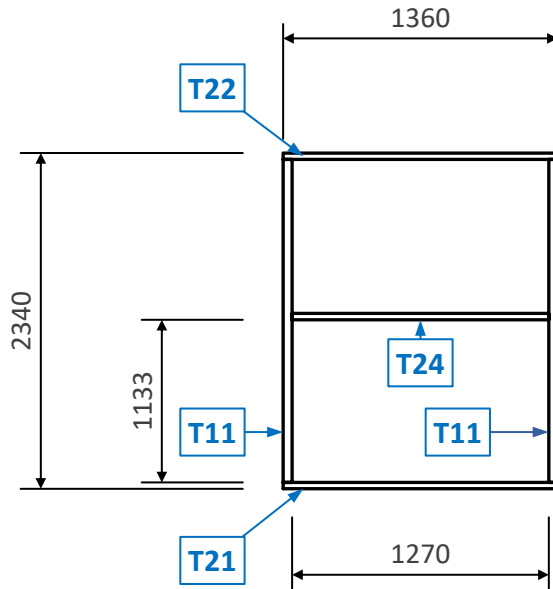

RIGHT WALL FRAMING LAYOUT

- Refer to Section 5.1 for general instructions on wall framing assembly.

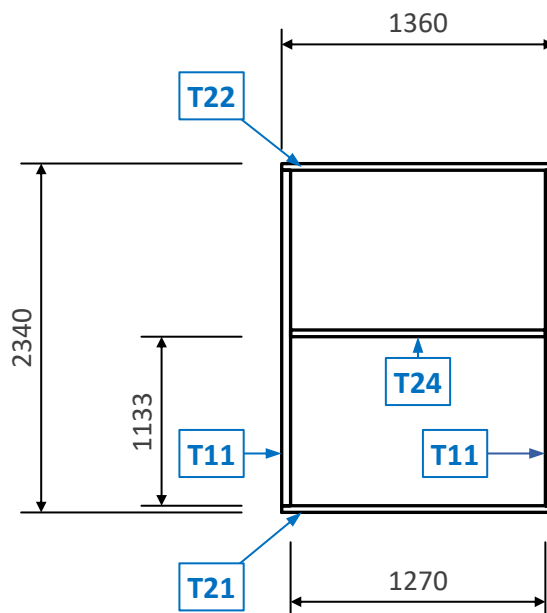

STUD TIES

- **Components Required**

- **A04** Stud Ties, **430mm** long:



- **H04** Bracket nails, 3.15 x 30mm:
12 are required for each Stud Tie.



- **Attach Stud Ties**

Attach stud ties to ALL studs *EXCEPT*:

Corner studs, door trimming studs, and studs adjacent to braces;

Install a U-Bracket formed from **A04** 430mm strap to secure stud to bottom plate.

- Place **A04** Stud Tie on the lower **125mm** of the stud.

- Fold sharply around the bottom plate, and overlap **125mm** to other side of stud.

- Fix to each sides of stud with 4 x **H04** bracket nails

- Fix to each side of plate with 2 x **H04** bracket nails

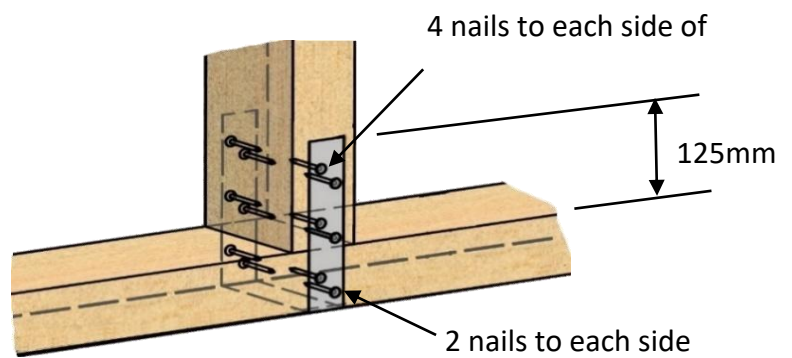
**DPC STRIPS**

- **Components Required**

- **A06** DPC roll

- **H03** 2.5 x 30mm fixing clouts



- **Attach DPC to Bottom Plates**

- Only attach the DPC (Damp Proof Course) after all Stud Ties have been fixed in place.

- Cut a strip of DPC material to the length of each wall panel but omit DPC under door opening, as the bottom plate will be removed from here later in construction.

- Use **H03** fixing clouts at each stud to nail the strip to the underside of the bottom plate.

- The strip should be flush with the outer edge of the bottom plate.

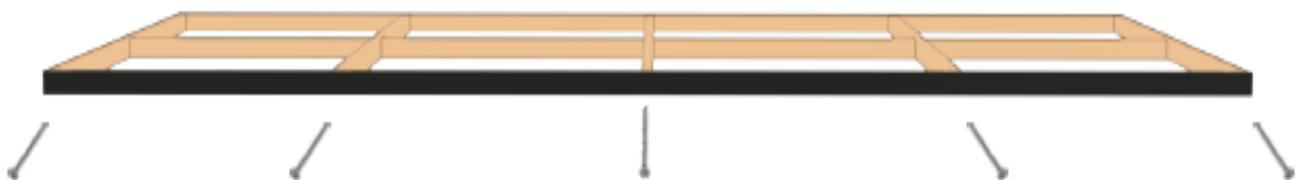

JOINING THE WALL FRAMES

- **Stand the Frames**
 - Stand the walls up on the base, in the correct relation to each other as shown below.
 - Use temporary braces to safely secure the walls in position while the corners are jointed.
 - Note that the Left and Right walls fit *between* the Front and Back Walls.

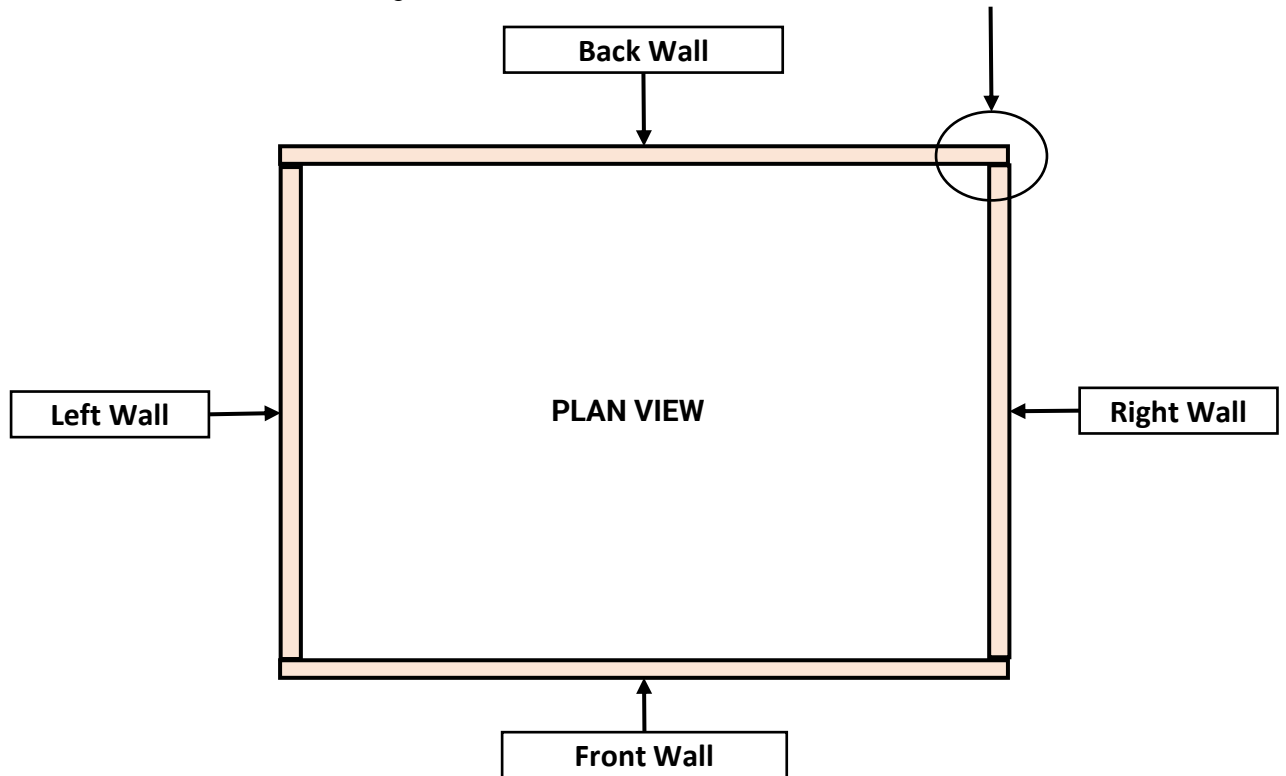

- **Join Frames at Corners**
 - Find the **H02 14g x 100mm Hex Head Screws**



- Pre-drill four 7.0mm diameter holes in the outer studs of the side-wall frames *only*, spaced evenly over the height of the stud, and **22mm** in from the outer edge of the stud.

- At each corner, insert **H02 14g x 100mm Tek Screws** through the pre-drilled holes.

- Use the cordless drill and 3/8" drive bit to screw into the end studs on the front and back walls.

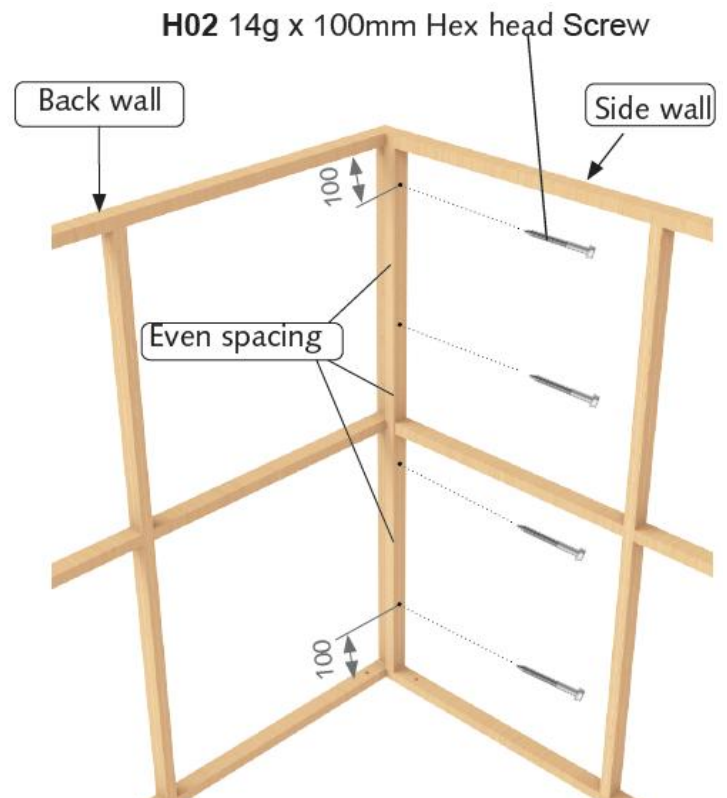

- **Position the Frames**

- First, position the framing so that it overhangs the slab equally (about 10mm) on opposite sides; left and right; and front and back.

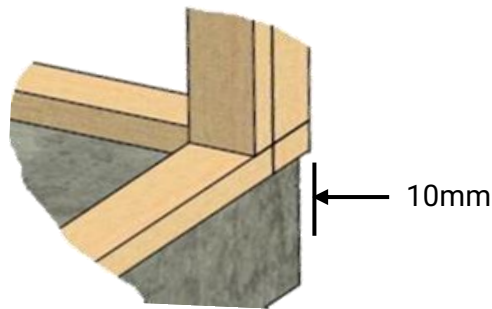

- Adjust the framing position if necessary to ensure the *diagonal* measurements from corner-to-corner are *equal*. This ensures the frame is square.

SECURING BOTTOM PLATE TO THE BASE

- **For all Base Types**

- The bottom plate is secured to the base with a fastener adjacent to each stud, *except* those studs with Structural brackets as per previous section.

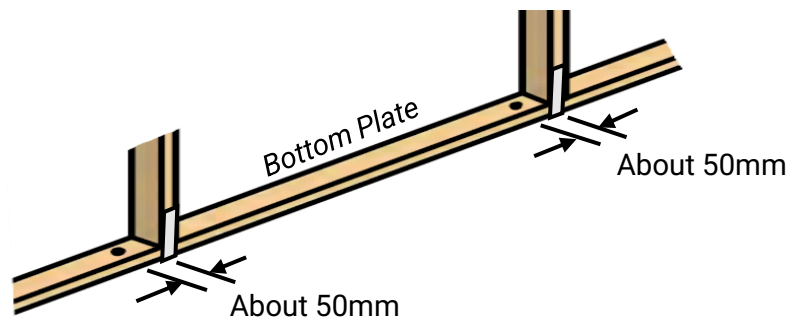

- **For Concrete Bases**

- Use **A03 M12 x 135mm Through-Bolts** where these have been provided (90mm framed sheds only). For other sheds on a concrete base, use a Duratuf Hold-Down Kit (not included in shed kitset) or other suitable concrete fasteners.



- Pre-drill a 13mm hole in the bottom plate within 50mm of one side of the stud.

- Use hammer drill and **12mm masonry** bit to drill into concrete base to 140mm depth. Clean out hole of dust and debris. Insert **A03 Through-Bolt** full depth. Tighten with spanner.

- **For Timber Bases (where applicable)**

- Use the Timber Screws supplied with your Base Kit and follow the Kit instructions.



COMPLETE FRAMING ASSEMBLY

The completed wall framing assembly should now look like this:

Note: If you have a Very High Wind Zone (VHWZ) kit, brace types and positions may differ from those shown below; refer to the instructions with the VHWZ kit.

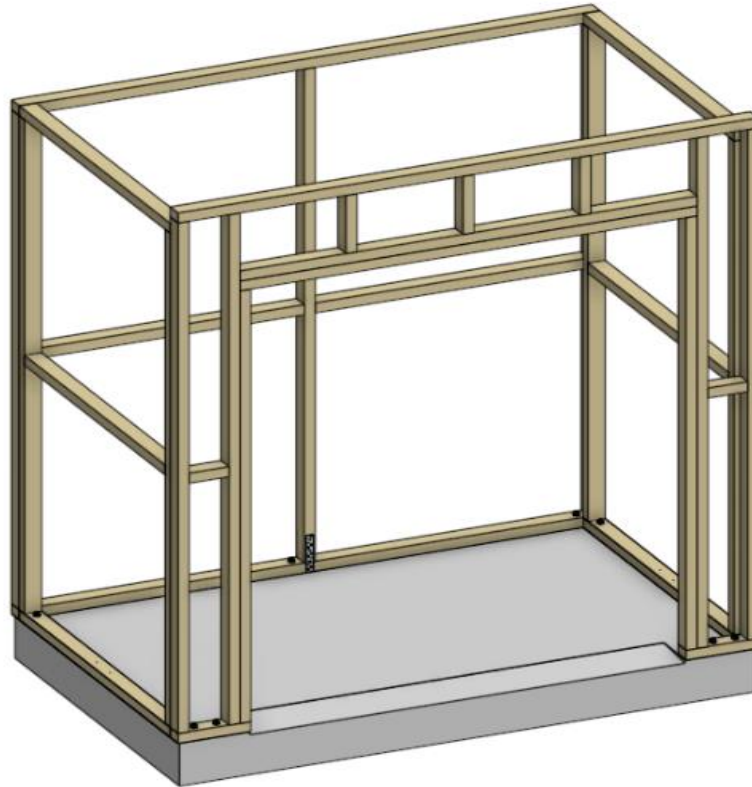

There are now just a few items to finish the timber wall framing ready for cladding installation:

FRAME FLASHINGS

- **Components**

- **F04** Door Head Flashing.
Length is equal to door opening width of 1800mm

- **H03** 2.5 x 30mm fixing clouts.

- **Fix Door Head Flashing**

- Fit the door head flashing to the underside and outer face of the Lintel as shown.

- Use 4 x **H03** fixing clouts into the face of the Lintel and 4 x to the underside.

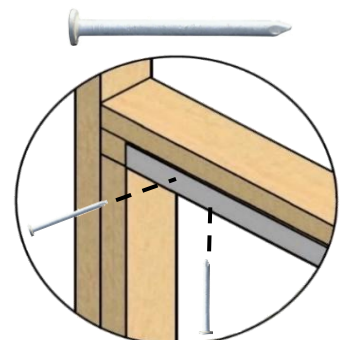
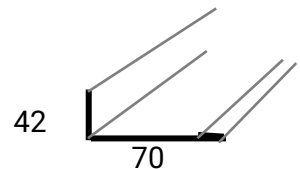

DPC TO STUDS

- **Components**

- H03 2.5 x 30mm fixing clouts.
- A06 DPC roll.



- **Cut Bottom Plate**

- Use hand saw to cut and remove the bottom plate between door studs.

- **Cut DPC Strips**

- Cut DPC strips for each corner of the shed. DPC should be level with top of top plate and 20mm below bottom of bottom plate.

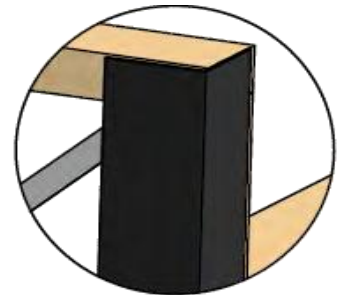

- Cut DPC strips for each side of each door opening. DPC should be level with bottom of lintel and 20mm below bottom of bottom plate.

- **Fix DPC to Studs**

- Fold each strip longitudinally down its centre to form a right angle.
- Using ten 30mm clouts per strip, attach DPC strips to each corner and door studs as shown.

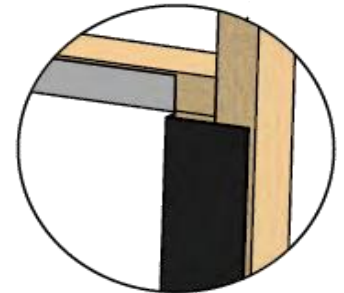

BUILDING PAPER

- Building paper (underlay) is not supplied as standard for Lifestyle sheds, however if you wish to fit building paper to the walls, do so now.
- First ensure the wall frames are square. Use packaging timber (or similar) as bracing and nail to inside of frame to temporarily hold wall panel square.
- Also tighten tensioners on any strap braces until straps are tight but do not overtighten.
- Building paper should be stapled to the outside of the timber framing before the cladding is installed.
- Remove any temporary bracing after cladding is fitted.

- **Fastenings**

- Use **H05** Wall Cladding screws, 25mm long



- **Fastener Pattern**

- External edges: use **H05** screws through every 2nd trough.
- Internal studs: use 2 x **H05** Screws per sheet, per stud.
- Top & bottom plate: use **H05** screws at every stud.

- **Fastening the Sheets**

- Re-check each wall frame for squareness and adjust if necessary.
- The cladding layout for each wall is shown on the following pages.
- Fix the top sheet first, it must be flush with the top of the top plate.
- Tip: Pre-drill the cladding using a 3.5mm drill bit for easy fastening.
- Do not screw off the lower edge of the sheet until the next row of sheeting is in place.
- Position the second row of sheets. Slip under the sheet above. Ensure sheet lower edges are at the distance from the top of the wall shown on the wall cladding layouts.
- Some sheets will need to overlap by more than one rib.
- Finish screwing off the sheet above, and repeat the process for the next lower row.
- Sheets next to openings are pre-cut, no cutting or trimming is required.
- Cladding will finish approximately 5 - 10mm above and below window framing.
- The lower edge of the bottom sheets will be about 30mm below the bottom plate.

IMPORTANT: Always ensure metal swarf has been removed from the cladding surface, from between sheets, and from under the heads of fasteners.

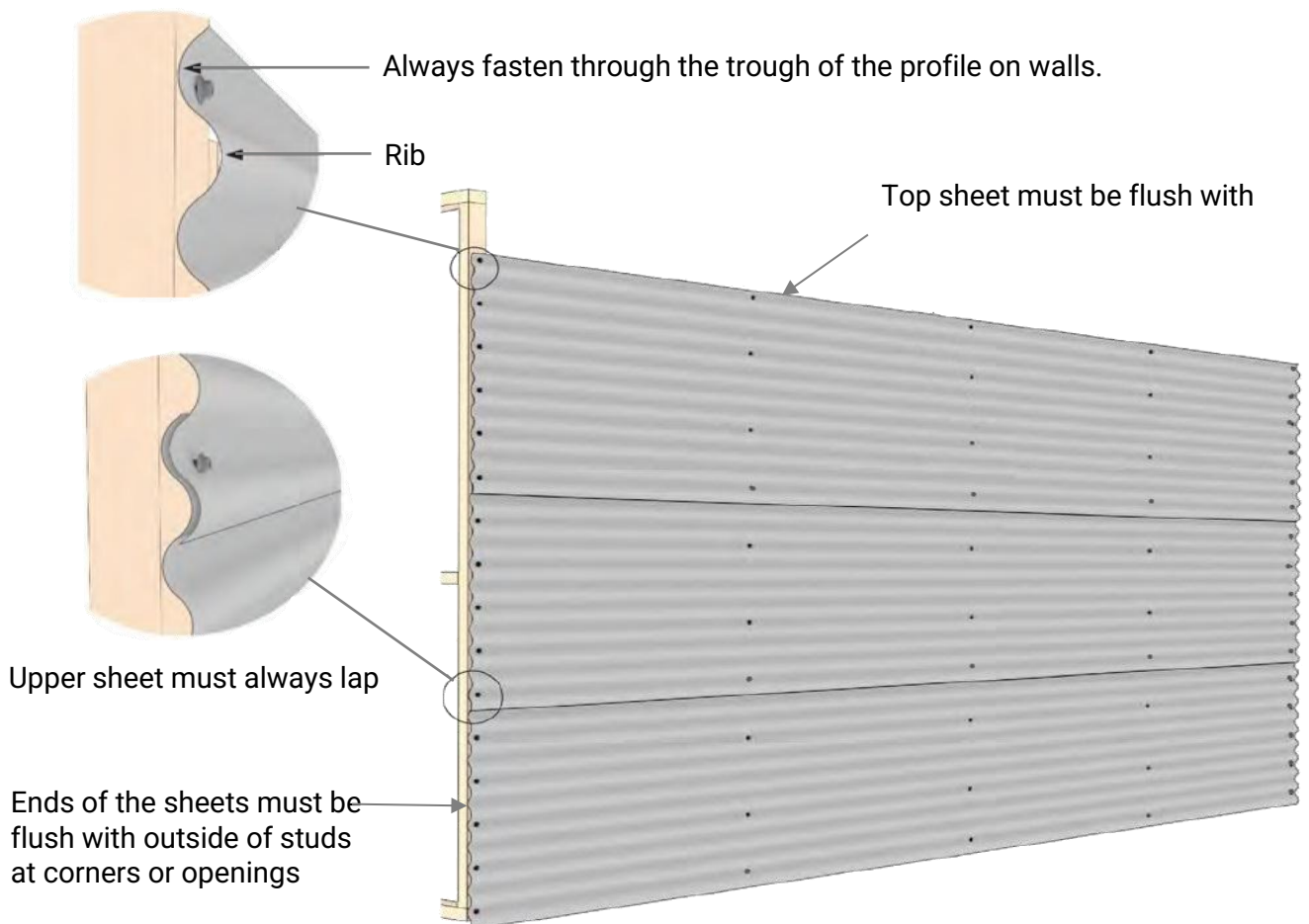

FRONT WALL CLADDING LAYOUT

- Refer to **Section 3.2** for Cladding sheet sizes, using the references given in **blue** below.
- Refer to **Section 6.1** for general instructions on cladding installation.
- Vertical Dimensions are to the visible bottom edges of the sheets

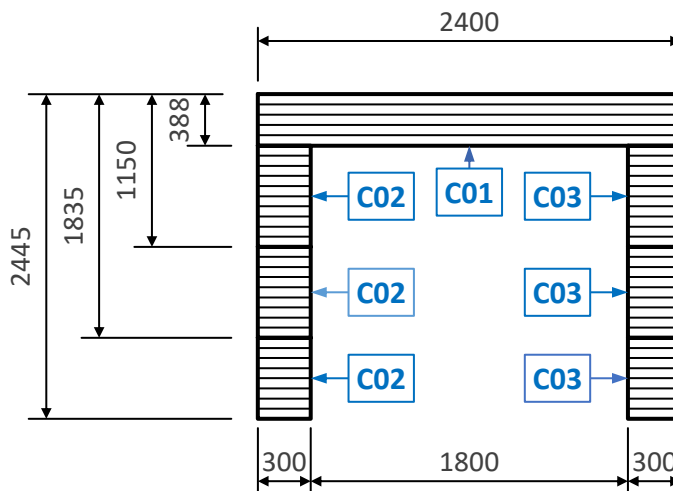

BACK WALL CLADDING LAYOUT

- Refer to **Section 3.2** for Cladding sheet sizes, using the references given in **blue** below.
- Refer to **Section 6.1** for general instructions on cladding installation.
- Vertical Dimensions are to the visible bottom edges of the sheets

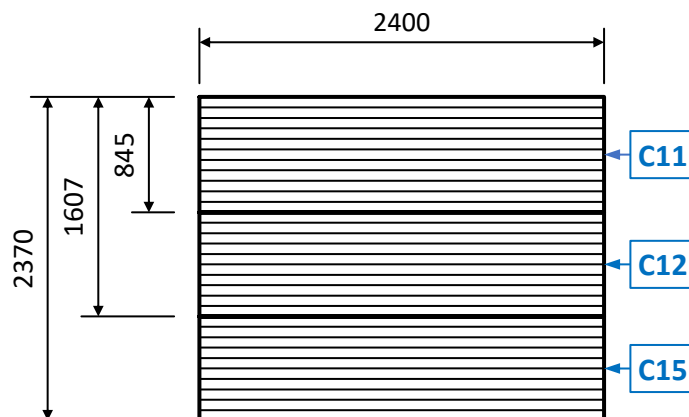

LEFT WALL CLADDING LAYOUT

- Refer to **Section 3.2** for Cladding sheet sizes, using the references given in **blue** below.
- Refer to **Section 6.1** for general instructions on cladding installation.
- Vertical Dimensions are to the visible bottom edges of the sheets

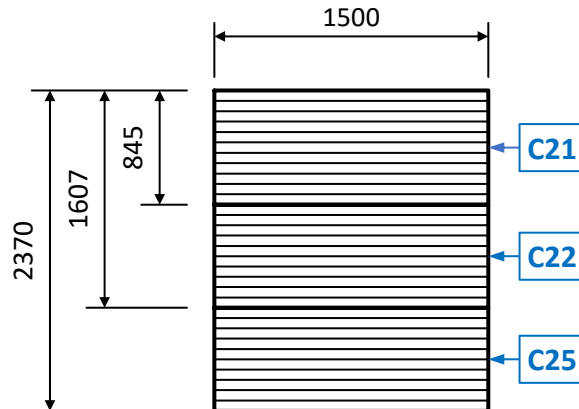





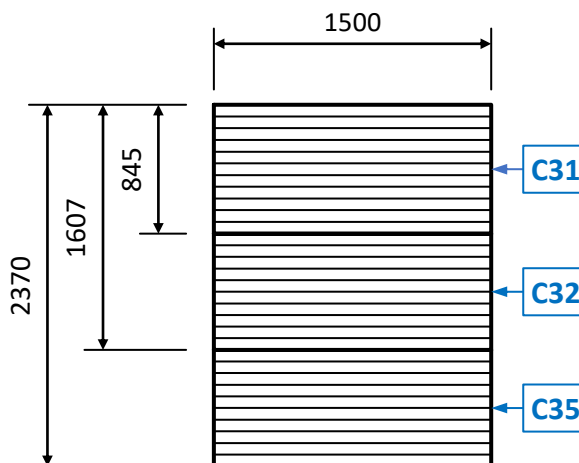

RIGHT WALL CLADDING LAYOUT

- Refer to **Section 3.2** for Cladding sheet sizes, using the references given in **blue** below.
- Refer to **Section 6.1** for general instructions on cladding installation.
- Vertical Dimensions are to the visible bottom edges of the sheets.

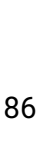

6.6 Top Plate, Corner, & Door Flashings

• **Components**

- **F02** Top Plate Flashing 2400mm long 
- Two **F01** Front Corner Flashings 2440mm long
- Two **F11** Back Corner Flashings 2365mm long
(both have the same profile) 
- **F03** Door Top Flashing 2000mm long 
- **F05** Door Jamb Flashing 2045mm long 
- **H03** 2.5 x 30mm fixing clouts 
- **H06** Roofing Screws, 55mm long 

• **Attach Top Plate Flashing**

- Position **F02** Top Plate Flashing on top of front wall. The flashing arm with a crushed end sits over the cladding. Fix with four **H03** clouts to top of top plate

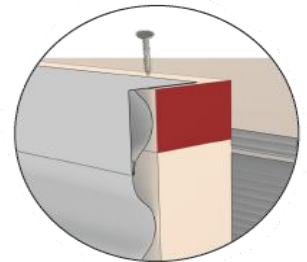

• **Attach Corner Flashings**

- Position **F01** and **F11** corner flashings over corners, ensuring they are square and parallel with wall panels and bottom of flashings are level with bottom of cladding.

- Fix with six **H06** Screws per flashing, spaced evenly over flashing height. Ensure screws pass through a rib of the cladding.

• **Attach Roller Door Flashings**

- Position **F05** Door Jamb flashing so top is level with underside of lintel. If required, notch bottom of flashing around the base using tin snips.

- Nail **F05** Door Jamb flashing to inside of stud using three **H03** clouts and screw into stud through front of wall cladding using three **H06** Screws. Screws should pass through a rib of the cladding.

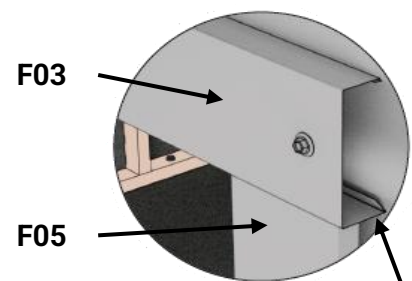

The arm of the flashing with a 45-deg return must go at the bottom!

- Sit **F03** Door Top flashing on top of the Door Jamb flashings and centralize. The arm of the flashing with a 45-deg return must go at the bottom! It will protrude about 10mm past the jamb flashings. Fix to lintel centrally on the 86mm face, using four **H06** screws; 1 each end and 2 spaced equally between.

7.1 Gutter Assembly

STANDARD

Components

- **F22** Gutter Flashing 2525 mm long
- **A13** Gutter End Caps, Zinc, two required
- **A21** Sealant Cartridge and nozzle
- **A15** Downpipe Dropper and Sleeve (supplied assembled)
- **A14** PVC White Downpipe, 3000mm long
- **A16** PVC Downpipe Brackets Two required
- **H07** Rivets
- **H03** 2.5 x 30mm fixing clouts

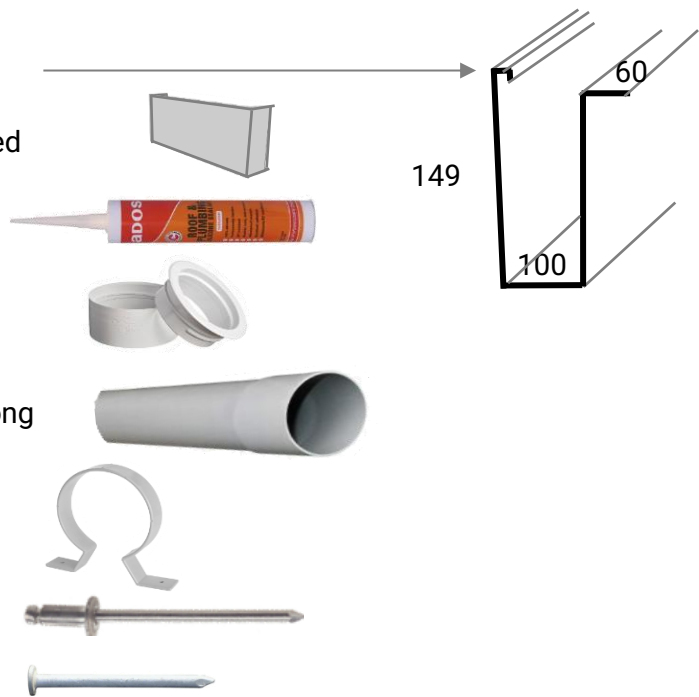

Gutter Assembly

- Position **A15** dropper anywhere on base of **F22** Gutter, at least 300mm from either end, centralized front and back. Unscrew sleeve from dropper and mark dropper diameter on base of Gutter. Drill a small hole, and using tin snips, cut a larger hole, slightly larger than the diameter of dropper.
- Silicon around the hole and insert **A15** dropper into hole. Screw sleeve onto dropper from underneath.
- Using tins snips cut two 50mm snips in each end of spouting as shown. Bend the tab between the snips upwards until it is 90° to the base of the spouting.
- Fit and rivet **A13** endcaps behind the tabs using 4 x **H07** rivets per endcap. Silicone endcaps to Gutter.

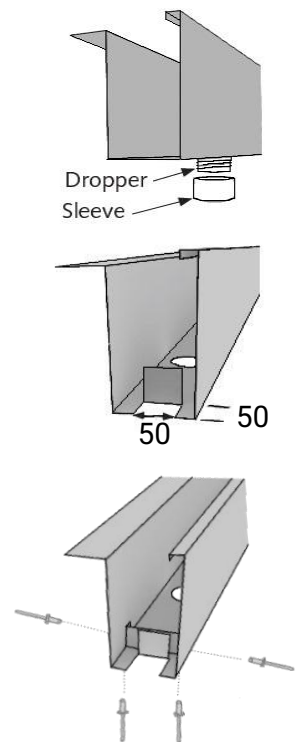

Gutter Installation

- Centralise Gutter assembly on top of back wall. Fix with 4x **H03** clouts. Gutter overhangs corner flashings ~25mm.
- Cut **A14** downpipe to length and fix to dropper with 1x rivet. Fix to back wall cladding using 2 x **A16** brackets. Rivet them to back wall cladding.

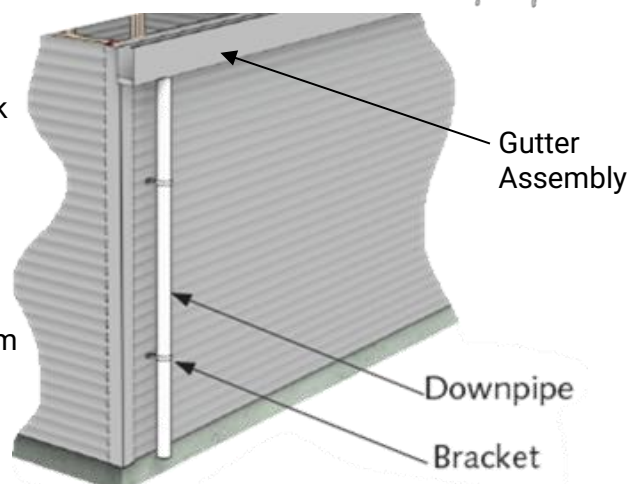

7.2 Roof Installation

Components

- **C41** Roof Sheets (and **C42** Clear Roof sheets, if applicable). See section 3.2.
- **H06** Roofing Screws, 55mm long
- **H13** Dome Washers for Clear sheets
- **H07** Rivets
- **F27** Gutter Straps, two required



Sheet Fastening

- Rafters must be straight before fixing roof sheets. Temporarily nail packing-crate timber under the rafters to hold them in position while the roof is fixed.
- Building paper is not supplied but may be fitted now to reduce condensation. Use 'self-supporting' paper.
- Start on one side and lay out **C41** Roof sheets. Each sheet overlaps the previous one by one or more ribs, and protrudes past the **F02** Top Plate flashing on the front wall as shown:
- Roof sheets may **overhang** the side wall framing slightly, or be **setback**, depending on the model. For your shed:
 - Edge sheets are setback by 16mm on both sides of shed.**
- Each sheet overlaps the next sheet by one rib as standard.

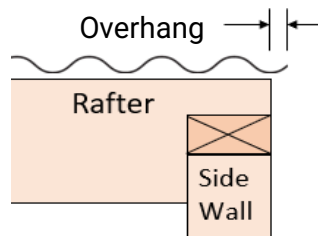
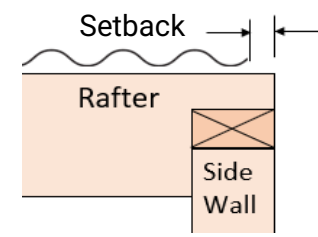
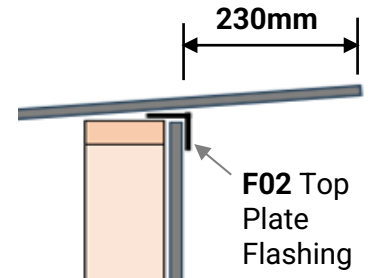

- Fix with **H06** Screws centrally on the ribs, in the pattern shown below, to each rafter and front and back wall plates:



Clear Roof Panels

- Position **C42** Clear Roof Panels (if any) where required, but not on the sides of the roof.



- Screws on any **C42** Clear sheets must be fitted with **H13** Dome Washers, after first removing the standard washers that come fitted to the screws.

Gutter Straps

- Space **F27** Gutter Strap(s) evenly along the Gutter length, with the colour side up.
- Rivet each strap with two **H07** Rivets to the top lip of the Gutter, and to the wall top plate through the roofing with one **H06** screw placed centrally on a rib.

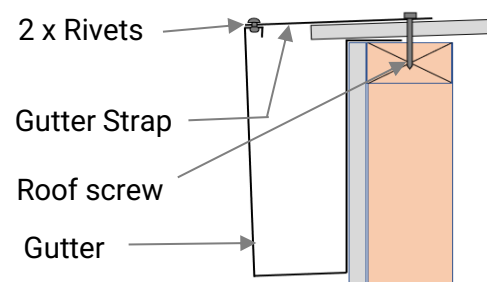

• Components

- 2 x **F24** Barge Flashing. 1895 mm long.

- 2 x **F25** Barge Support Flashings.
Note the following models do NOT have Barge Supports:
Ponsonby, Fendalton, Windsor, Cardrona, Matakana, Milford, Tamahere, Waimate, Marlborough, Kaipara.

- **F21** Front Fascia. 2525 mm long.

- **H06** Roofing Screws, 55mm long

- **H05** Wall Cladding screws, 25mm

- **H07** Rivets

- **A12** Barge Corner Jointer 145mm

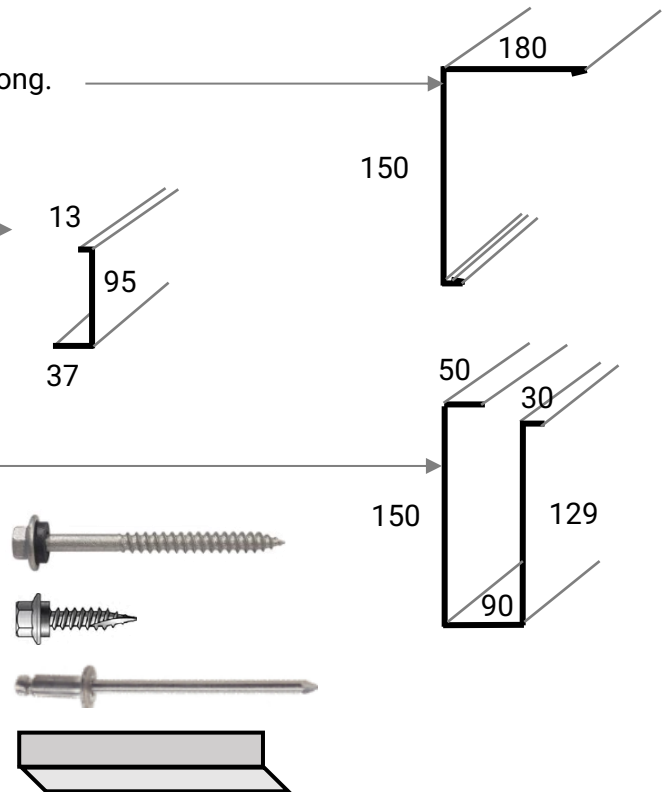

• Install Barge Flashings

- If **F25** Barge Support flashings are supplied, fit now.

- Position one on each side of shed so bottom of barge support flashing is 129mm below top of rafters and/or front and back wall framing, parallel with roof, and central between corner flashings.

- Attach barge support to wall cladding with 5 x **H07** rivets

- Fit **F24** Barge over roof cladding and **F25** Barge Supports (if any). Where no Barge Support, Barge lower edge sits against the corner flashings.

- **F24** Barge also fits over the **F22** Gutter, with its end flush with outer face of the Gutter. The Gutter and Barge should form a neat corner joint.

- Fit **A12** Barge Corner Jointer 145mm to inside of Gutter/Barge joint and rivet to both, to hold the corner joint together without a gap.

- Use **H06** Screws to secure barge flashings through roof sheets into the rafters, and into the top plates of the front and back walls.

- Secure **F24** Barge to **F25** Barge Support (if any) with 6 x **H07** Rivets.

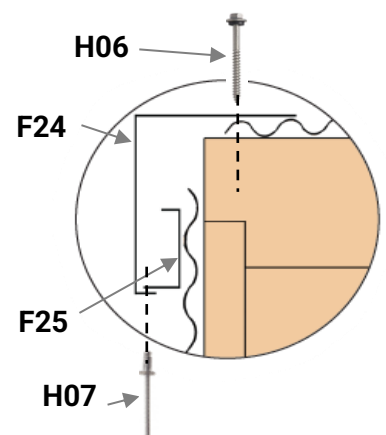
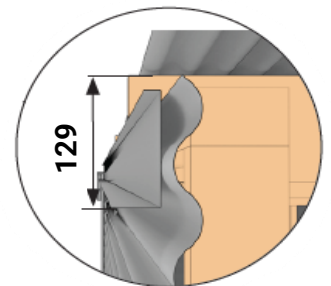

- **Install Fascia Flashing**

- Fit the **F21** Fascia flashing to the top end of the roof sheets as shown:

- At each end, the top lip of the **F21** Fascia Flashing should sit over the **F24** Barge Flashings, and the lower lip of the fascia should sit inside the lower lip of the Barge Flashing.

- Align the outer face of the **F21** Fascia with the ends of the **F24** Barge Flashings.

- Fit **A12** Barge Corner Jointer to inside of Fascia/Barge joint and rivet to both, to hold the corner joint together without a gap. It will be necessary to rivet to one flashing first, then reassemble the joint and rivet to the other.

- Fasten upper lip of the **F21** Fascia to the top of the roof sheeting, one **H05** 25mm Screw in the centre of each sheet. Fasten through the ribs.

- Fasten the lower lip of the **F21** Fascia to the *underside* of the roof sheets using **H07** rivets, 3 rivets per sheet, equally spaced. Fasten through the sheet troughs.

- Fasten the Fascia and barge together using an **H05** 25mm screw top and bottom as shown:

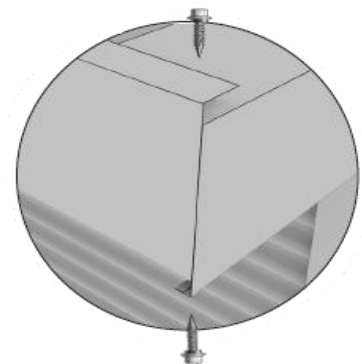
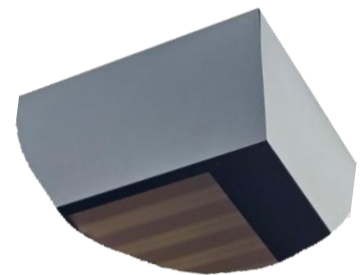
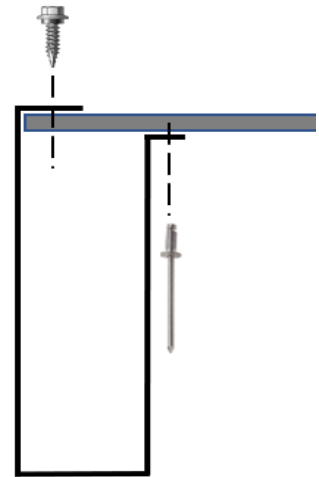

- **Clean-up**

- Remove all swarf (drill filings) with a soft brush or rag.

- Hose down roof and walls thoroughly.

- For coloured sheds, use touch-up paint provided on all rivets and exposed cuts.

8.1 Roller Door Parts List

Windsor - 1BBB

STANDARD

Scan this QR code to watch a video on roller door installation:

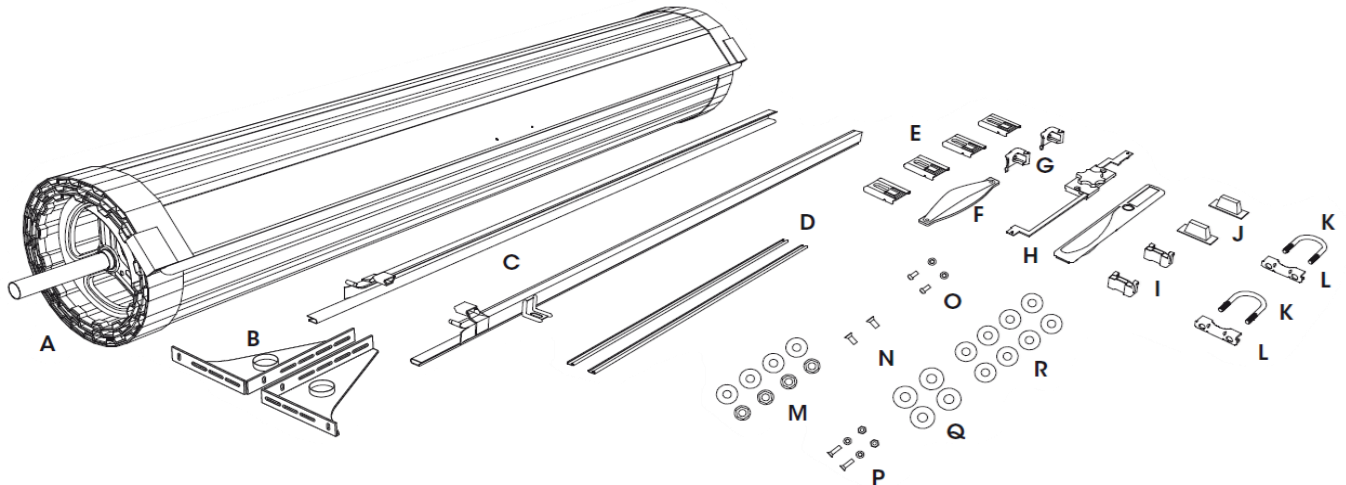

| Series 1 Roll-A-Door Parts List | | |
|---------------------------------|--|----------|
| Item | Description | Quantity |
| A | Rolled plastic wrapped door | 1 |
| B | "A" Style brackets, left and right hand | 2 |
| C | Doors guides, left and right handed | 2 |
| D | Steel locking bars | 2 |
| Small parts bag | | |
| E | Guide clips (Qty is door size dependent) | 4 - 10 |
| F | Door handle and fixing to suit | 1 |
| G | Bottom rail stops and 6mm screws | 2 |
| H | Faceplate and fixing to suit | 1 |
| I | Locking bar retainer | 2 |
| J | Locking bar covers | 2 |
| K | U-Bolts | 2 |
| L | Axle / Bracket saddles | 2 |
| M | 8mm Nuts for U-bolts | 4 |
| N | Counter sunk screws for lock and facia | 2 |
| O | 7mm x 4mm Mushroom head screws for locking bar | 2 |
| P | 4mm x 6mm Screws for handle | 2 |
| Q | 10mm Washers | 4 |
| R | 8mm Washers (Qty is door size dependent) | 8 - 12 |
| S | Plastic Clamp | 1 |
| T | 14g x 50mm Coach screws | 18 |

Also prepare a 400mm long wooden chock, with one end mitred as shown, as an installation aid:



- **Preliminary**
 - **Ensure the Door opening is SQUARE and LEVEL!**
 - Measure the opening width.
 - Measure the door curtain width.
 - Calculate overlap for each side: $(\text{Door width} - \text{Opening width}) \div 2 = \text{Overlap}$
 - Mark the line for the edge of door curtain (overlap) on each side of the opening.
 - **CAUTION: Do not cut the door plastic wrap or packaging yet!**

- **Install Brackets**

- Position bracket (B) centre on outer stud, approximately 140mm up from bottom of lintel and 80mm from inside of door opening to outside of bracket.

- Mark 2 hole positions using the bracket's top and bottom

- Drill both holes, then attach bracket using 14gx50mm coach screws and 10mm washers.

- Install second bracket as above and make sure it is **exactly level with the first bracket.**

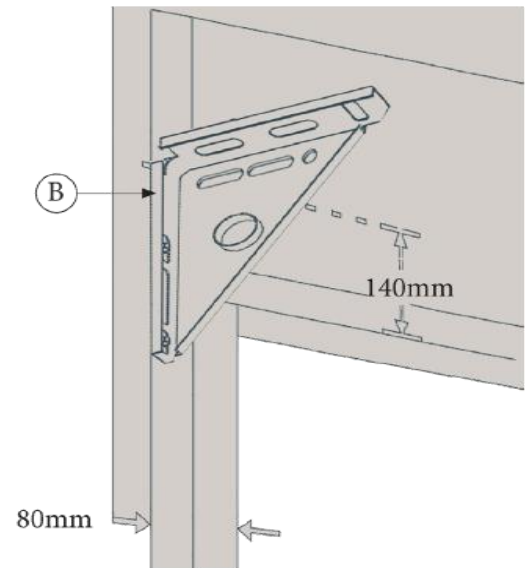

- **Placing Door on Brackets**

- Make sure the axle is free and centred. Centre will be found by rotating the axle a quarter turn in either direction then releasing. With centre found, make a clear mark on the axle against the hub for later reference.

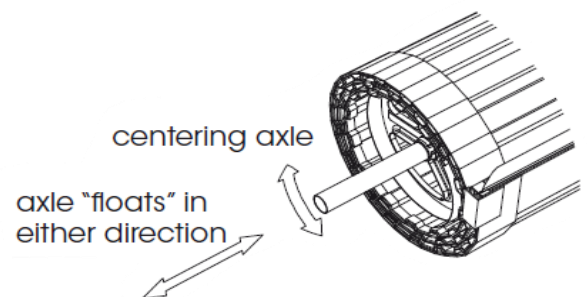

- Using 2 persons and correct lifting techniques, lift door onto brackets (right way around, so door will roll down from the front of the opening).

- Immediately loosely fit "U" bolts (K), saddles (L), washers and nuts (M) to the brackets in position shown. Fitting "U" bolts eliminates the door falling from the brackets. (Do not tighten yet.)

Note: When correctly positioned, the roll may come down a little lower than the underside of the lintel. However it should not come down lower than the bottom of the curtain when fully opened.

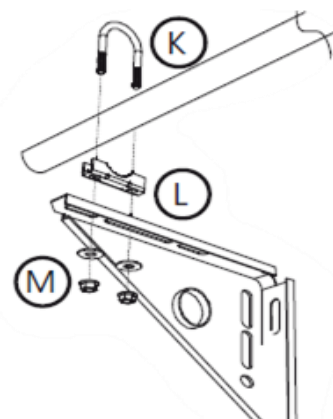
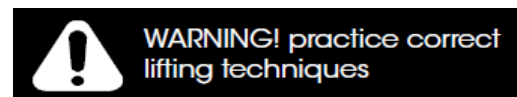

8.3 Door Placement

- **Placing Door on Brackets**

- Centre the door with the opening, while ensuring the floating axle is also centred with the door. Do this by lining up previous marks with the hub, then lift both the axle and the door together until it is centred with the opening.

- Rotate the curtain and axle so that the bottom rail of the door is positioned as shown at 3 o'clock.

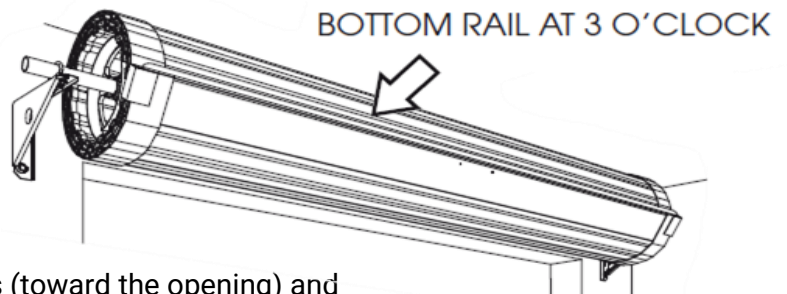

- Push the axle forward in the slots (toward the opening) and tighten the nuts firmly without overtightening.

- **Tensioning the Springs**

- Ensure that the bottom rail is at the 3 o'clock position as shown in previous step

- Ensure both "U" bolts are tightened, then:

- Rotate the door 1½ turns in a forward direction to apply tension. Do not let go as the springs are now tensioned. See arrow in diagram:

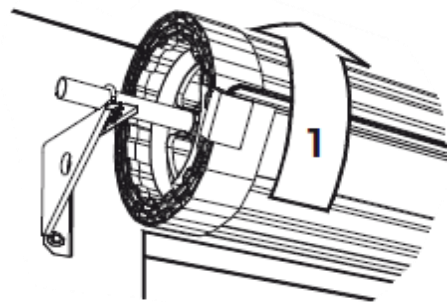

- Hold the door firmly, NOW cut the plastic wrap along the bottom rail (taking care not to damage door surface or weatherseal).

- Pull the curtain down slowly and carefully; position the wooden chock as shown. Take care not to damage door surface. The chock will help hold the door until the guides and stops are fitted.

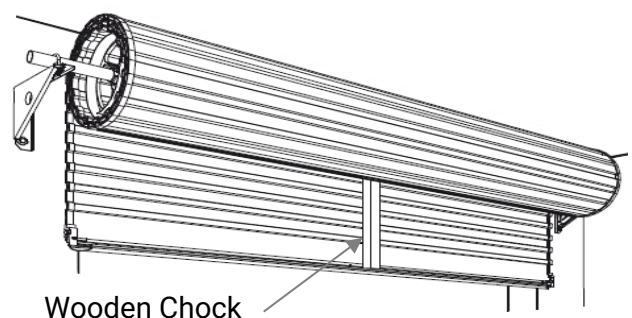

- **Attach Bottom Rail Stops**

- Hook the stop (G) behind lip in rail, as shown

- Secure from underneath the rail with 6mm screws (G) supplied.

- You will need to trim the weatherseal flush with the end of the bottom rail.

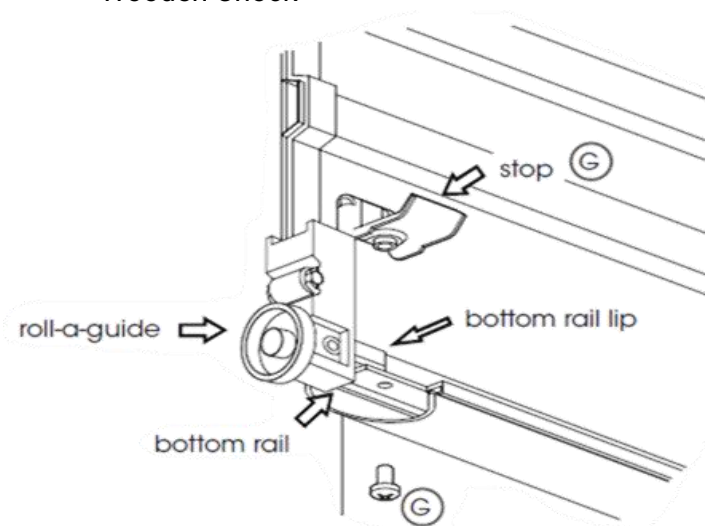

• Installing the Guides

- Ensure curtain overlaps equally on both sides, and cut the guides the correct length (top of guides is level with top of the brackets while the guides bottom is touching the floor).

- Slide two guide clips (E) into each guide (C).
Position bottom clip 200mm from floor with the rest evenly spaced along the guide.

- Position one guide over the edge of the door curtain. Mark and drill the top fixed guide clip and secure it using 14g coach screw and washer, allowing 3mm clearance between inside of guide and plastic roll-a-guide. Ensure guide is plumb, then drill and fix remaining clips. Repeat with second guide.

- Remove the wooden chock and slowly lower the door, removing the plastic wrap as you pull the door down. Reposition the guides as necessary to allow smooth and even operation with 0 - 1mm clearance.

- Ensure door curtain enters guides smoothly. It will be necessary to adjust the guide lead in to achieve this.

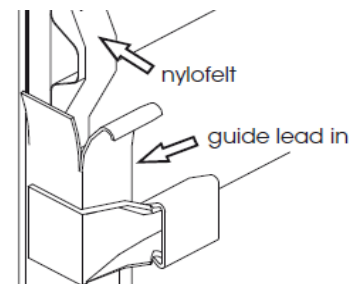
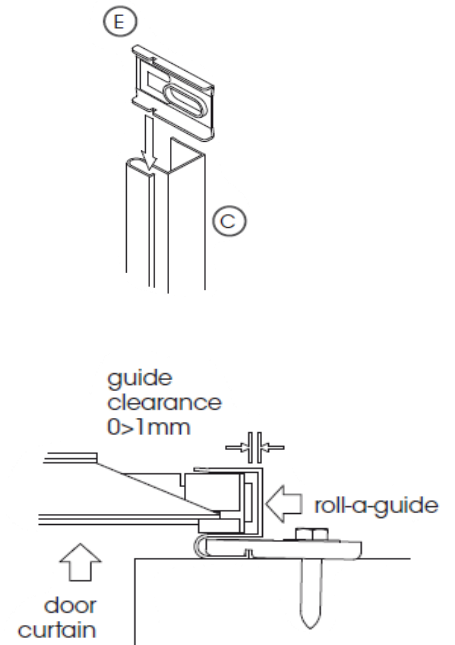

• Fitting Handle

- Fit handle (F) to the outside of the door using the supplied screws (P), nuts, and washers.

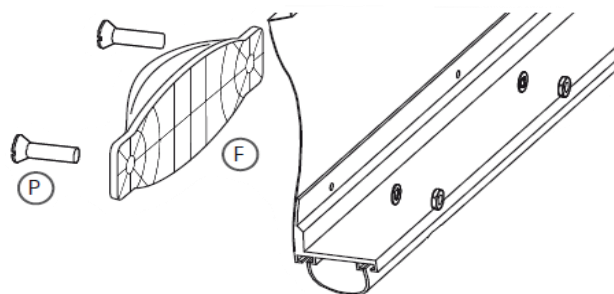

8.5 Fitting Centre Lift Lock

Windsor - 1BBB

STANDARD

CAUTION: Wear appropriate gloves as some edges of the door are very sharp!

- Raise the curtain until the lock corrugation is visible above door guides.

- Install locking bar retainer (I) in line with lock corrugation by pushing retainer towards door edge, sliding the legs under the Nylofelt® and hooking them over the curtain edge. Ensure lock bar retainers sit squarely on door curtain.

- Fit faceplate (H) to outside of door, where the hook will latch onto curtain edge. Then, slide the faceplate as far to the right as possible. Use adhesive tape on outside to hold in position.

- Attach the lock body (H) to the faceplate from the inside, using the mounting screws and washers. Do not overtighten the screws.

- With the door in the closed position, slide the end of the locking bars (D) through the locking bar retainers, and while holding the bars level, mark the side of the guides.

- Drill and file out a rectangular slot in the guide, no longer than 25mm or wider than 10mm, ensuring top of the slot remains in line with top of the locking bar.

- Slide bars through the guide slot, then back onto locking arms.

- Screw on securely using the countersunk screws (O). Ensure locking bars do not protrude more than 20mm beyond guide when engaged in locked position. It may be necessary to adjust the length of the bars.

- Ensure the guide is clean and dry using a clean rag. Peel lining from adhesive tape on lock bar cover (J) and position over hole. Ensure locking bars move freely.

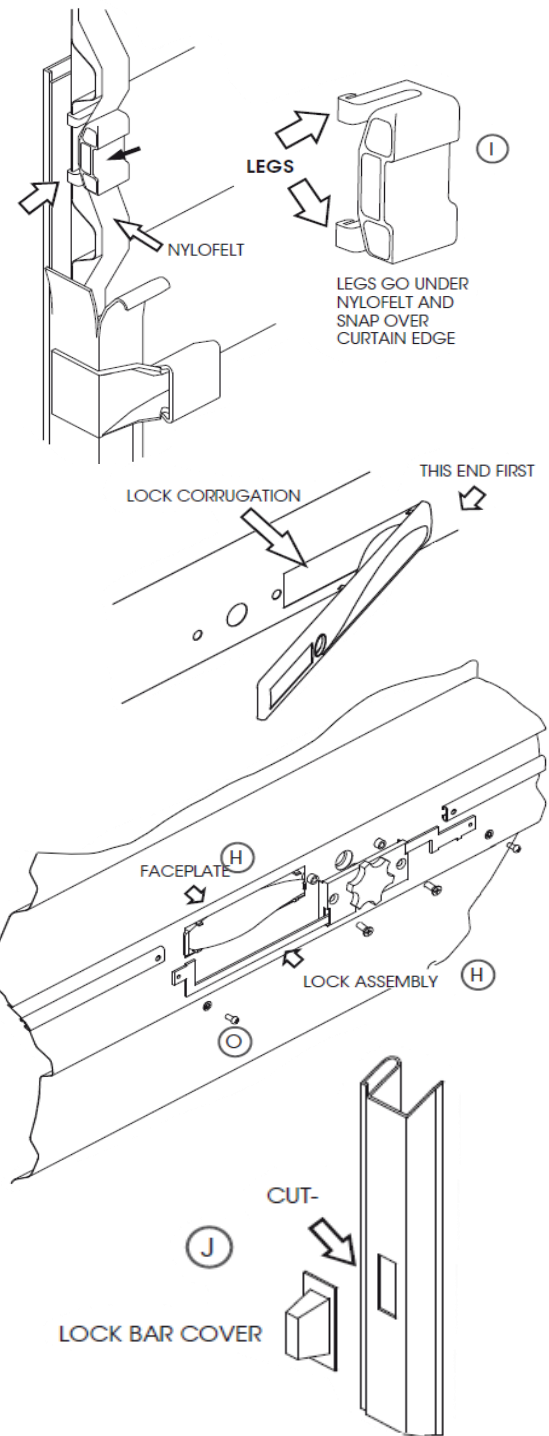

Lock Bar Cover must be installed to prevent finger

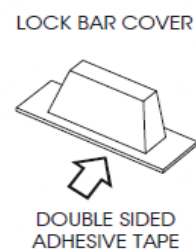

- **Troubleshooting Guide**

| Symptom | Possible Cause | Remedy |
|--|------------------------------------|---|
| Door is hard to operate in BOTH directions | Door is jamming in the guides | a) Check Guide Clearances |
| | | b) Check Guides are plumb |
| | | c) Check guide surfaces are clean and free from oil |
| | | d) Check locking bars are correct length |
| | | e) Check weatherseal is correct length |
| The door is hard to operate in ONE direction | Spring tension requires adjustment | a) If door is hard to lift, but tends to drop, refer to 'Adjusting Spring Tension' below to increase spring tension. |
| | | b) If door is hard to close, but tends to rise, refer to 'Adjusting Spring Tension' below to decrease spring tension. |
| The door rolls up crooked | Brackets are not level | Make sure brackets are level. |
| | Guides are not plumb | Make sure the guides are plumb. |
| | Axle is not centred | Refer to section 'Centralise the axle when Door is mounted' below. |

- **Centralise the Axle when Door is mounted**

WARNING! Ensure that pipe wrench is fitted correctly to the axle and if it is gripped onto the axle, do not underestimate the tension in the spring when undoing the clamps.

CAUTION: THIS ADJUSTMENT REQUIRES 2 PERSONS TO COMPLETE.

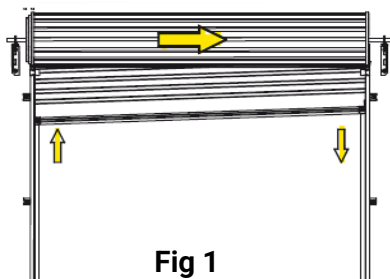

Fig 1

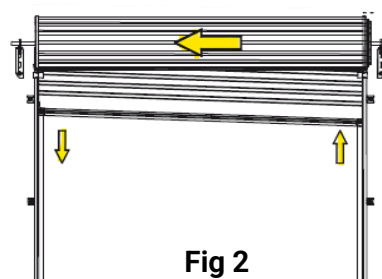

Fig 2

- If the door rolls up crooked with one side higher than the other, proceed as follows:
- Roll the door up as high as possible and tie two ropes around the door roll approximately 300mm from each end, as a safety precaution.
- With a person at each end of the door, hold the axle firmly with a large pipe wrench (Stillson) at least 450mm long.
- Loosen the "U" bolt nuts at both ends and **KEEP A FIRM GRIP ON WRENCH.**
- If the door rolls up crooked with the RIGHT HAND SIDE higher than the left, move the axle 20 - 40mm to the RIGHT, as per Fig 1 above.
- If the door rolls up crooked with the LEFT HAND SIDE higher than the right, move the axle 20 - 40mm to the LEFT, as per Fig 2 above.
- Re-tighten "U" bolts before releasing pipe wrench.
- Test and repeat if further adjustment is needed.
- If the door is stiff to work or rattles over lead-in on top of guide, refer to next section.

- **Adjusting Spring Tension**

WARNING! Ensure that pipe wrench is fitted correctly to the axle and if it is gripped onto the axle do not underestimate the tension in the spring when undoing the clamps.

CAUTION: THIS ADJUSTMENT REQUIRES 2 PERSONS TO COMPLETE.

- Roll the door up as high as possible and tie two ropes around the door roll approximately 300mm from each end, as a safety precaution.
- With a person at each end of the door, hold the axle firmly with a large pipe wrench (Stillson) at least 450mm long.
- Loosen the "U" bolt nuts at both ends and **KEEP A FIRM GRIP ON WRENCH.**
- Rotate the axle in the required direction (see diagram).
- Re-tighten the "U" bolts **BEFORE** releasing pipe wrench.
- Test and repeat if further adjustment is necessary.

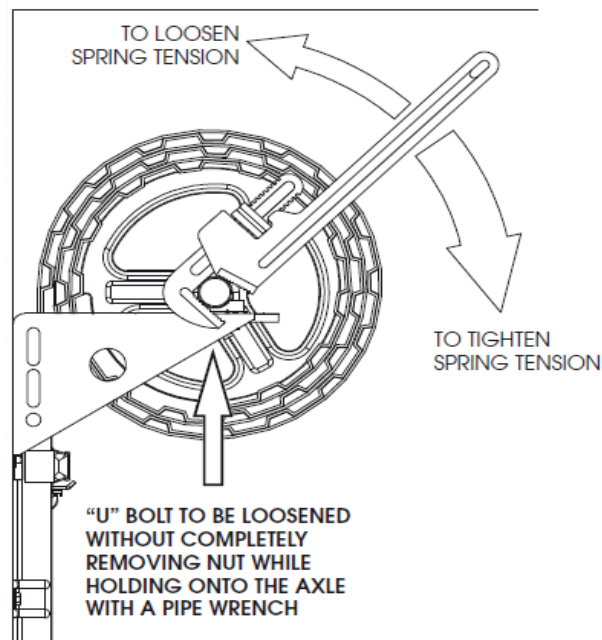

If you need professional assistance to install or remedy the roller door, please call your nearest Garador or Dominator Garage door dealer as listed on these web pages:



1. Duratuf warrants that their Lifestyle sheds will be free from manufacturing defects for **30 years**. This warranty also covers components which are missing or damaged at time of despatch from the factory.
2. Duratuf warrants the durability of the structural framing for **30 years**.
3. Duratuf warrants that the metal roofing and wall cladding will not perforate due to corrosion within the following periods:
 - Standard Non-Coastal Warranty – **30 years** if located greater than 2,000m from saltwater, or **15 years** if located between 1,000m and 2,000m from saltwater.
 - With Coastal Upgrade Option – **30 years** if located greater than 1,000m from saltwater, or **15 years** if located between 250m and 1,000m from saltwater.

WARRANTY TERMS AND CONDITIONS

- The warranty is not transferrable and only valid for the original purchaser. Proof of purchase and proof of damage or defect is required to submit a claim. Warranty periods begin at the date of manufacture.
- This warranty is in addition to your rights under New Zealand consumer law and must be registered within 90 days from purchase to be valid. Refer to the warranty registration guidance below. All claims must be made in writing within 30 days of discovery. Interference with the product or other action taken to remedy a defect prior to Duratuf being notified of the suspected defect and Duratuf being given a reasonable time to inspect the product in situ will invalidate a claim.
- For the warranty to be valid, the recommendations in our **Kitset Care Guide** <https://www.duratuf.co.nz/kitset-care-guide/> and the **Assembly Care Instructions** given in the Assembly Instruction booklet must be followed; and the **Minimum Maintenance** in accordance with instructions below must be performed for the life of the product.
- Except as provided otherwise by NZ law, the liability of Duratuf is limited to replacing or repairing any defective or missing product. Any repaired or replaced material will be covered only by the balance of the original warranty period. Duratuf will not be liable for any consequential loss or damage, or labour costs. Transport charges will apply to our nearest reseller only.
- The structural framing and cladding warranties are subject to the shed being installed on a level concrete base, or other solid supports, at least 40mm above ground level, and contact being prevented at all times with soil, vegetation, organic matter, fertilizers, or other moisture retaining substances.
- In the rare event of a claim and upon receiving proof of purchase and defect, Duratuf will at its option repair or replace defective parts, or provide a prorated refund for the remaining life of the applicable warranty. Any replacement product provided will be covered by the Warranty for the balance of the Warranty term as if the replaced product were original product.
- Duratuf reserves the right to inspect the shed in situ at the installation site and to conduct tests at any time after a Warranty claim is received. Any interference with the shed prior to inspection by Duratuf may void a claim under this Warranty.
- Any product replaced under this Warranty becomes the property of Duratuf.
- Any failure, delay, or indulgence by Duratuf will not operate as a waiver. A waiver by Duratuf of any condition of this Warranty is not a waiver of any other condition. No waiver is effective unless it is in writing.
- All terms, conditions, warranties, undertakings, inducements, and representations other than contained in this warranty, whether express or implied, statutory, or otherwise, are expressly excluded.
- This Warranty does not exclude, restrict, or modify any liability that cannot be excluded, restricted, or modified at law.

EXCLUSIONS FROM WARRANTY COVER

- Normal wear and tear. Fading, chalking, or discolouration of the cladding. Minor white corrosion at cuts or bends.
- Cladding perforation in areas where severe or very severe environmental situations are extended inland by local conditions.
- Timber floors, where used for storage of other than normal lightweight household items.
- This warranty will not apply if the failure or defect is caused or contributed to by an event or action beyond the reasonable control of Duratuf, including without limitation:
 - Any modification of the shed structure or cladding different from the design provided in the assembly instructions.
 - Mechanical, chemical, or other damage sustained after despatch from Duratuf's factory.
 - Problems resulting from misuse or use for purposes other than normal dry storage use.
 - Fire, flood, storm, cyclone, earthquake or other 'Acts of God.'

MINIMUM MAINTENANCE REQUIREMENTS

- All metal swarf must be cleaned off the shed IMMEDIATELY.
- Wash all external surfaces using a soft nylon brush with water every 12 months, or for locations within 2 km of saltwater, wash every 3 months. After a storm, wash the cladding and the gutters as soon as possible to remove any salt deposits.
- A low-pressure water spray may also be used, less than 10 MPa (1500 psi or 100 Bar).
- Outdoor cleaning detergents may be used if they do not contain bleach, chlorine, or other harmful chemicals.
- Volcanic ash fallout and pollen deposits—wash as soon as possible, removing all deposits from roof and gutters.
- Gutters and channels to be kept clear of leaves and dirt at all times.
- Remove any lichen or mould: First wash off any loose growth with a brush and water. Apply diluted bleach (sodium hypochlorite) at 2% solution. A small amount of household detergent (no more than 5-7 ml per litre of water) may be added to the solution to improve wetting. Leave for 5 minutes. Wash down with copious amounts of clean water.
- Remove and replace any fasteners, washers, or fittings showing signs of corrosion.

WARRANTY REGISTRATION

Go to <https://duratuf.co.nz/warranty> to register the Warranty within 90 days of purchase. Alternatively, call us on **0800 438 274**. It is important to keep your proof of purchase as it will be required in the unlikely event of a claim.

Thank you for investing in a Duratuf Lifestyle Range Shed.
We are sure that it will provide excellent long-term storage and add value to your property.

To continually improve our products and service, we would love to hear about your Duratuf experience and why you chose us.
Please scan the below QR code to fill out the survey. Thank you for your feedback!

